



## Undercounter Ice Machines

### Technician's Handbook





## Safety Notices

### Read these precautions to prevent personal injury:

- Read this manual thoroughly before operating, installing or performing maintenance on the equipment. Failure to follow instructions in this manual can cause property damage, injury or death.
- Routine adjustments and maintenance procedures outlined in this manual are not covered by the warranty.
- Proper installation, care and maintenance are essential for maximum performance and trouble-free operation of your equipment.
- Visit our website [www.icetroamerica.com](http://www.icetroamerica.com) for manual updates.
- This equipment contains high voltage electricity and refrigerant charge. Installation and repairs are to be performed by properly trained technicians aware of the dangers of dealing with high voltage electricity and refrigerant under pressure. The technician must also be certified in proper refrigerant handling and servicing procedures. All lockout and tag out procedures must be followed when working on this equipment.
- This equipment is intended for indoor use only. Do not install or operate this equipment in outdoor areas.
- As you work on this equipment, be sure to pay close attention to the safety notices in this handbook. Disregarding the notices may lead to serious injury and/or damage to the equipment.

## Warning

**Follow these electrical requirements during installation of this equipment.**

- All field wiring must conform to all applicable codes of the authority having jurisdiction. It is the responsibility of the end user to provide the disconnect means to satisfy local codes. Refer to rating plate for proper voltage.
- This appliance must be grounded.
- This equipment must be positioned so that the plug is accessible unless other means for disconnection from the power supply (e.g., circuit breaker or disconnect switch) is provided.
- Check all wiring connections, including factory terminals, before operation. Connections can become loose during shipment and installation.
- For a cord-connected appliance, the following must be included:
  - Do not unplug by pulling on cord. To unplug, grasp the plug, not the cord.
  - Unplug from outlet when not in use and before servicing or cleaning.
  - Do not operate any appliance with a damaged cord or plug, or after the appliance malfunctions or is dropped or damaged in any manner. Contact the nearest authorized service facility for examination, repair, or electrical or mechanical adjustment

## **Warning**

**Follow these precautions to prevent personal injury during installation of this equipment:**

- Installation must comply with all applicable equipment fire and health codes with the authority having jurisdiction.
- To avoid instability the installation area must be capable of supporting the combined weight of the equipment and product. Additionally the equipment must be level side to side and front to back.
- Use appropriate safety equipment during installation and servicing. Two or more people are required to lift or move this appliance to prevent tipping and/or injury.
- Do not damage the refrigeration circuit when installing, maintaining or servicing the unit.
- Connect to a potable water supply only.
- This equipment contains refrigerant charge.

## **Warning**

**Follow these precautions to prevent personal injury while operating or maintaining this equipment.**

- Legs or casters must be installed and the legs/casters must be screwed in completely. When casters are installed the mass of this unit will allow it to move uncontrolled on an inclined surface. These units must be tethered/secured to comply with all applicable codes. Swivel casters must be mounted on the front and rigid casters must be mounted on the rear. Lock the front casters after installation is complete.
- Refer to nameplate to identify the type of refrigerant in your equipment.
- Only trained and qualified personnel aware of the dangers are allowed to work on the equipment.
- Read this manual thoroughly before operating, installing or performing maintenance on the equipment. Failure to follow instructions in this manual can cause property damage, injury or death.
- Crush/Pinch Hazard. Keep hands clear of moving components. Components can move without warning unless power is disconnected and all potential energy is removed.
- Moisture collecting on the floor will create a slippery surface. Clean up any water on the floor immediately to prevent a slip hazard.

## Warning

**Follow these precautions to prevent personal injury while operating or maintaining this equipment.**

- Objects placed or dropped in the bin can affect human health and safety. Locate and remove any objects immediately.
- Never use sharp objects or tools to remove ice or frost.
- Do not use mechanical devices or other means to accelerate the defrosting process.
- When using cleaning fluids or chemicals, rubber gloves and eye protection (and/or face shield) must be worn.

## DANGER

Do not operate equipment that has been misused, abused, neglected, damaged, or altered/modified from that of original manufactured specifications. This appliance is not intended for use by persons (including children) with reduced physical, sensory or mental capabilities, or lack of experience and knowledge, unless they have been given supervision concerning use of the appliance by a person responsible for their safety. Do not allow children to play with, clean or maintain this appliance without proper supervision.

## DANGER

Follow these precautions to prevent personal injury during use and maintenance of this equipment:

- It is the responsibility of the equipment owner to perform a Personal Protective Equipment Hazard Assessment to ensure adequate protection during maintenance procedures.
- Do Not Store Or Use Gasoline Or Other Flammable Vapors Or Liquids In The Vicinity Of This Or Any Other Appliance.
- Never use flammable oil soaked cloths or combustible cleaning solutions for cleaning.
- All covers and access panels must be in place and properly secured when operating this equipment.
- Risk of fire/shock. All minimum clearances must be maintained. Do not obstruct vents or openings.
- Failure to disconnect power at the main power supply disconnect could result in serious injury or death. The power switch DOES NOT disconnect all incoming power.
- All utility connections and fixtures must be maintained in accordance with the authority having jurisdiction.
- Turn off and lockout all utilities (gas, electric, water) according to approved practices during maintenance or servicing.
- Units with two power cords must be plugged into individual branch circuits. During movement, cleaning or repair it is necessary to unplug both power cords.

# Table of Contents

## General Information

<b>Model Numbers</b> .....	14
<b>How to Read a Model Number</b> .....	15
<b>How to Read a Serial Number</b> .....	16
<b>Ice Cube Sizes</b> .....	17
Model & Serial Number Location .....	17

## Installation

<b>Location of Ice Machine</b> .....	18
<b>Ice Machine Clearance Requirements</b> .....	19
<b>Ice Machine Heat of Rejection</b> .....	19
<b>Leveling the Ice Machine</b> .....	20
<b>Electrical Requirements</b> .....	21
<b>Electrical Specifications</b> .....	21
<b>Water Service/Drains</b> .....	22
Water Supply .....	22
Water Inlet Line .....	22
Drain Connections .....	23
<b>Water Supply &amp; Drain Line Sizing/Connections</b> .....	24

## Maintenance

<b>Interior Cleaning &amp; Sanitizing</b> .....	25
<b>Detailed Cleaning &amp; Sanitizing Procedure IC/IU-0170 &amp; IC/IU-0220</b> .....	25
Remedial Cleaning .....	26
Cleaning the Condenser .....	36
Removal from Service/Winterization .....	37
Bin Removal .....	48
<b>Detailed Descaling and Sanitizing Procedure WU-0100</b> .....	40
Cleaning The Condenser .....	51
Removal from Service/Winterization .....	52

## Operation

### Sequence of Operation

<b>IC/IU-0170 &amp; IC/IU-0220</b> .....	53
Main Power Switch .....	53
Sequence of Operation .....	55
Error Codes .....	61
Troubleshooting Error Codes .....	63
<b>Operational Checks</b> .....	65
Ice Thickness Check .....	65
Ice Thickness Adjustment .....	65
Minimum/Maximum Slab weight .....	67
<b>Sequence of Operation WU-0100</b> .....	68
WU-0100 Energized Parts Chart .....	70
<b>Operational Checks WU-0100</b> .....	72
Siphon System .....	72
Water Level .....	72
Water Level Check .....	73
Ice Thickness Check .....	74

## Troubleshooting

<b>Troubleshooting IC/IU-0170 &amp; IC/IU-0220</b> .....	75
Control Board (IC/IU-0170 & IC/IU-0220) .....	77
Diagnosing an Ice Machine that Will Not Run .....	80
Ice Machine Does Not Cycle Into Harvest when the Harvest Float is down/closed .....	81
Ice Machine Does Not Cycle Into Harvest when Water Touches Ice Thickness Probe.....	82
Ice Machine Cycles Into Harvest Before the Harvest Float is down/closed.....	83
Ice Production Check .....	85
Installation/Visual Inspection Checklist .....	87
Water System Checklist .....	87
Ice Formation Pattern .....	89

Analyzing Discharge Pressure .....	91
Analyzing Suction Pressure .....	93
Hot Gas Valve .....	96
Discharge Line Temperature Analysis .....	100
Final Analysis .....	102
<b>Troubleshooting WU-0100 .....</b>	<b>103</b>
Diagnosing An Ice Machine That Will Not Run .....	103
Error Codes .....	104
Error Code Checklist .....	105
Diagnosing Ice Thickness Control Circuitry	108
Ice Production Check .....	110
Installation/Visual Inspection Checklist .....	112
Water System Checklist .....	113
<b>WU-0100 Refrigeration Diagnostics .....</b>	<b>115</b>
Analyzing Discharge Line Temperature .....	116
Analyzing Suction Line Temperature .....	117
Hot Gas Valve .....	119

## Component Check Procedures

Main Fuse .....	123
Bin Switch All Models .....	124
Float Switch	
IC/IU-0170 & IC/IU-0220 .....	126
Water Trough Thermistor	
IC/IU-0170 & IC/IU-0220 .....	128
ICE/OFF/WASH Toggle Switch	
All Models .....	129
Compressor Electrical Diagnostics.....	130
High Pressure Cutout (HPCO) Control	
IC/IU-0170 & IC/IU-0220 .....	132
<b>Filter-Driers .....</b>	<b>133</b>
<b>Refrigerant Recovery/Evacuation .....</b>	<b>134</b>
Refrigerant Re-use Policy .....	135
Recovery and Recharging Procedures	
IC/U-0170 & IC/IU-0220 .....	137
Recovery and Recharging Procedures	
WU-0100 .....	140
<b>System Contamination Cleanup</b>	
Mild System Contamination Cleanup .....	144
Severe System Contamination Cleanup .....	145
Replacing Pressure Controls Without	
Removing Refrigerant Charge .....	147
<b>Total System Refrigerant Charge .....</b>	<b>148</b>

## Charts

<b>Cycle Times, 24 Hr. Ice Production and Refrigerant Pressure Charts</b> .....	149
WU-0100 .....	150
IC/ID-0170 & IC/ID-0220 .....	151

## Diagrams

<b>Wiring Diagrams</b> .....	152
WU-0100 Wiring Diagram .....	153
IU-0170 & IU-0220 Wiring Diagram .....	154

### Printed Circuit Boards (PCB)

WU-0100 PCB .....	155
IC/IU-0170 & IC/IU-0220 PCB (Floats) .....	156
IU-0170 & IU-0220 PCB (Ice Thickness Probe) .....	157

### Tubing Schematics .....

Tubing Schematic - WU-0100 .....	158
Tubing Schematic IC/IU-0170 & IC/IU-0220 .....	159

THIS PAGE INTENTIONALLY LEFT BLANK

# General Information

## Model Numbers

This manual covers the following models:

<b>Self-contained Air-cooled</b>	<b>Self-contained Water-cooled</b>
WU-0100A	–
IC-0170A	–
IU-0170A	–
IC-0220A	–
IU-0220A	–

## Ice Machine Warranty Information

For warranty information visit:

<http://www.icetroamerica.com/service-support>

- Warranty Registration
- Warranty Procedure Form
- Warranty Claim Form
- Labor Allowance Form

Warranty coverage begins the day the ice machine is installed.

# How to Read a Model Number

## Full Model Number

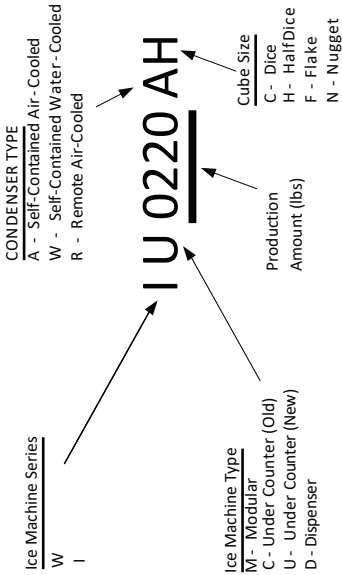

# How to Read a Serial Number

## Full Serial Number

First Letter	O	P	Q	R	S	T	U	V	W	X	Y	Z
Manufacture Year	2015	2016	2017	2018	2019	2020	2021	2022	2023	2024	2025	2026

Second Letter	A	B	C	D	E	F	G	H	I	J	K	L
Manufacture Month	JAN	FEB	MAR	APR	MAY	JUN	JUL	AUG	SEP	OCT	NOV	DEC

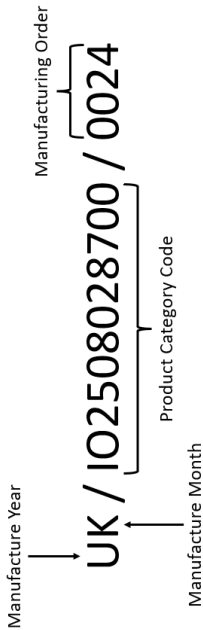

## Ice Cube Sizes

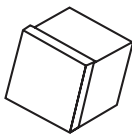

Dice

$7/8" \times 7/8" \times 7/8"$   
2.22 x 2.22 x 2.22 cm

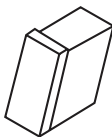

Half Dice

$3/8" \times 1-1/8" \times 7/8"$   
0.95 x 2.86 x 2.22 cm

## Model/Serial Number Location

These numbers are required when requesting information from your local Icetro Distributor, service representative, or Icetro America.

The model and serial number are listed on the OWNER WARRANTY REGISTRATION CARD.

They are also listed on the MODEL/SERIAL NUMBER DECAL, which can be found behind the air grill toward the bottom of the machine (IC/IU-0170 & IC/IU-0220), as well as behind the machine (all models).

# Installation

## Location of Ice Machine

The location selected for the ice machine must meet the following criteria. If any of these criteria are not met, select another location.

- The location must be indoors.
- The location must be free of airborne and other contaminants.
- Air temperature: Must be at least 50°F (10°C) but must not exceed 100°F (37.°C).
- The location must not be near heat-generating equipment or in direct sunlight.
- The location must be capable of supporting the weight of the ice machine and a full bin of ice.
- The location must allow enough clearance for water, drain, and electrical connections in the **rear of the ice machine**.
- The location must not obstruct airflow through or around the ice machine (condenser airflow is in and out the front). Refer to the chart below for clearance requirements.
- The ice machine must be protected if it will be subjected to temperatures below 32°F (0°C). Failure caused by exposure to freezing temperatures is not covered by the warranty.

## Ice Machine Clearance Requirements

	<b>Self-contained Air-cooled</b>	<b>Self-contained Water-cooled</b>
Top/Sides	5" (127 mm)*	5" (127 mm)*
Back	5" (127 mm)*	5" (127 mm)*

\*The ice machine may be built into a cabinet.

## Ice Machine Heat of Rejection

<b>Series Ice Machine</b>	<b>Heat of Rejection*</b>	
	<b>Air Conditioning**</b>	<b>Peak</b>
WU-0100	1750	2600
IC-0170	2200	2600
IU-0170	2200	2600
IC-0220	2800	3600
IU-0220	2800	3300

\* B.T.U./Hour

\*\* Because the heat of rejection varies during the ice making cycle, the figure shown is an average.

Ice machines, like other refrigeration equipment, reject heat through the condenser. It is helpful to know the amount of heat rejected by the ice machine when sizing air conditioning equipment where self-contained air-cooled ice machines are installed.

## Leveling the Ice Machine

1. Screw the legs onto the bottom of the ice machine.
2. Screw the foot of each leg in as far as possible.

### **Caution**

The legs must be screwed in tightly to prevent them from bending.

3. Move the ice machine into its final position.
4. Level the ice machine to ensure that the drain system functions correctly. Use a level on top of the ice machine. Turn each foot as necessary to level the ice machine from front to back and side to side.

## Electrical Requirements

### Voltage

The maximum allowable voltage variation is  $\pm 10\%$  of the rated voltage on the ice machine model/serial number plate at start-up (when the electrical load is highest).

### Fuse/Circuit Breaker

A separate fuse/circuit breaker must be provided for each ice machine.

### Total Circuit Ampacity

The total circuit ampacity is used to help select the wire size of the electrical supply.

The wire size (or gauge) is also dependent upon location, materials used, length of run, etc., so it must be determined by a qualified electrician.

## Electrical Specifications

### Air-cooled Ice Machine

Ice Machine	Voltage Phase Cycle	Min. Fuse/Circuit Breaker
WU-0100	115/1/60	15
IC-0170	115/1/60	15
IU-0170	115/1/60	15
IC-0220	115/1/60	15
IU-0220	115/1/60	15

NOTE: Model/serial plate information overrides all data listed in this chart.

## Water Service/Drains

### WATER SUPPLY

Local water conditions may require treatment of the water to inhibit scale formation, filter sediment, and remove chlorine odor and taste.

#### **Important**

If you are installing an Icetro water filter system, refer to the Installation Instructions supplied with the filter system for ice making water inlet connections.

#### **⚠ Warning**

For ice making, connect to a potable water supply only.

### Water Inlet Line

Follow these guidelines to install water inlet lines:

- Do not connect the ice machine to a hot water supply. Be sure all hot water restrictors installed for other equipment are working. (Check valves on sink faucets, dishwashers, etc.)
- If water pressure exceeds the maximum recommended pressure, 80 psig (5.5 bar) install a water pressure regulator.
- Install a water shut-off valve for ice making potable water.
- Insulate water inlet line to prevent condensation.

## Drain Connections

Follow these guidelines when installing drain lines to prevent drain water from flowing back into the ice machine and storage bin:

- Drain lines must have a 1/4" drop per foot of run and must not create traps.
- The floor drain must be large enough to accommodate drainage from all drains.
- Install a tee to vent the ice machine drain to the atmosphere.
- Insulate drain lines to prevent condensation.

 **Caution**

Plumbing must conform to state and local codes.

## Water Supply and Drain Line Connections

Location	Water Temperature	Water Pressure	Ice Machine Fitting
<b>Ice Making</b>	50°F (10°C) min.	20 psi (138 kPa) min.	3/8" Female Pipe Thread
<b>Water Inlet</b>	90°F (32°C) max.	80 psi (550 kPa) max.	3/4" Female Pipe Thread
<b>Bin Drain</b>	---	---	---

# Maintenance

## Interior Cleaning and Sanitizing

### General

Descal and sanitize the ice machine every six months for efficient operation. If the ice machine requires more frequent descaling and sanitizing, consult a qualified service company to test the water quality and recommend appropriate water treatment.

The ice machine must be taken apart for descaling and sanitizing.

#### **Caution**

Use only nickle safe ice machine cleaner and sanitizer. It is a violation of Federal law to use these solutions in a manner inconsistent with their labeling. Read and understand all labels printed on bottles before use.

### Detailed Descaling and Sanitizing Procedure IC-0170/IU-0170/IC-0220/IU-0220

Ice machine cleaner/descaler is used to remove lime scale and mineral deposits. Ice machine sanitizer disinfects and removes algae and slime.

NOTE: IC-0170/IU-0170/IC-0220/IU-0220 start on the following page.

WU-0100 starts on page 40.

## Initiating 'WASH' Operation

Please follow the preceding steps to initiate and complete the 'WASH' cycle on your Ictro ice machine.

**Step 1** Set the 'ICE/OFF/WASH' switch to 'OFF' and wait for the ice machine to stop after the harvest cycle ends and ice falls from the evaporator.

### **Caution**

Never use anything to force ice from the evaporator. Damage may result.

**Step 2** Remove all ice from the bin.

### **Warning**

Wear rubber gloves and safety goggles (and/or face shield) when handling Ice Machine Cleaner or Sanitizer.

 **Caution**

Do not mix Ice Machine Cleaner and Sanitizer solutions together. It is a violation of Federal law to use these solutions in a manner inconsistent with their labeling.

**Step 3** To start a cleaning cycle, set the 'ICE/OFF/WASH' switch to 'WASH'. Water will flow into the trough until it satisfies the float switch(s). The water pump will energize and begin to circulate the water/cleaning solution mixture throughout the water circuit.

<b>Model</b>	<b>Amount of Cleaner/Descaler Part Number 9405463</b>
IC-0170	5 ounces (150 ml)
IU-0170	5 ounces (150 ml)
IC-0220	5 ounces (150 ml)
IU-0220	5 ounces (150 ml)

Wait until the cycle is complete (approximately 21 minutes) then set the 'ICE/OFF/WASH' switch to 'OFF' and disconnect power before moving on to step 4.

**Step 4** Remove parts for descaling. Refer to the proper parts removal for your machine. Continue with step 5 when the parts have been removed.

**Step 5** Mix a solution of cleaner and warm water. Depending on the amount of mineral buildup, a larger quantity of solution may be required. Use the ratio in the table below to mix enough solution to thoroughly descale all parts.

<b>Solution Type</b>	<b>Water</b>	<b>Mixed with</b>
Cleaner	1 gal. (4 l)	16 oz (500 ml) cleaner

 **Caution**

Do not immerse electrical connectors or motors for any components in water, cleaner, or sanitizer solutions.

Use half of the cleaner and water solution to descale all components. The solution will foam when it contacts lime scale and mineral deposits; once the foaming stops use a soft bristle brush, sponge or cloth (not a wire brush) to carefully descale the parts. Soak the parts for 5 minutes (15 – 20 minutes for heavily scaled parts). Rinse all components with clean water.

**Step 6** While components are soaking, use half of the cleaner and water solution to descale all foodzone surfaces of the ice machine and bin. Use a nylon brush or cloth to thoroughly descale the following ice machine areas:

- Evaporator plastic parts – including top, bottom and sides
- Bin bottom, sides and top
- Rinse all areas thoroughly with clean water.

**Step 7** Mix a solution of sanitizer and warm water.

<b>Solution Type</b>	<b>Water</b>	<b>Mixed With</b>
Sanitizer	3 gal. (12 l)	2 oz (60 ml) sanitizer part number 9405653

Use half of the sanitizer/water solution to sanitize all removed components. Use a spray bottle to liberally apply the solution to all surfaces of the removed parts or soak the removed parts in the sanitizer/water solution. Do not rinse parts after sanitizing.

**Step 8** Use half of the sanitizer/water solution to sanitize all foodzone surfaces of the ice machine and bin. Use a spray bottle to liberally apply the solution. When sanitizing, pay particular attention to the following areas:

- Evaporator plastic parts - including top, bottom and sides
- Bin bottom, sides and top

**Do not rinse the sanitized areas.**

**Step 9** Replace all removed components, wait 10 minutes, then reapply power to the ice machine

**Step 10** Set the 'ICE/OFF/WASH' switch to 'WASH'. Water will flow into the through until it satisfies the float switch(s). The water pump will energize and begin to circulate the water/sanitizer solution mixture throughout the water circuit.

<b>Model</b>	<b>Amount of Sanitizer Part Number 9405653</b>
IC-0170	2 ounces (60 ml)
IU-0170	2 ounces (60 ml)
IC-0220	2 ounces (60 ml)
IU-0220	2 ounces (60 ml)

Wait until the sanitize cycle is complete (approximately 21 minutes) then set the 'ICE/OFF/WASH' switch to 'ICE' to start ice making.

## Remove Parts for Descaling

### **Warning**

Disconnect electrical power to the ice machine at the disconnect/breaker box before proceeding.

1. Remove the Low-Level/Harvest Float Switch and High-Level/Ice Thickness Float Switch (older models).
  - Pull forward on the bottom of the bracket until clear of the tab, then slide bracket upward to remove the bracket and float as an assembly. At this point, the float switches can easily be descaled. If complete removal is desired, follow the wires through the bulkhead grommet (exit point) in the back wall. Continue to follow the wires to the back of the machine (will need to remove the back panel) then disconnect the wire connector at the wire harness.

**NOTE:** Newer models will only have one float switch for monitoring the water fill and an ice thickness probe to initiate harvest.

- Do not disassemble float for descaling - Incorrect reassembly will result in an ice machine that will not harvest.
- The high-level/ice thickness float must be mounted to the front of the water trough.
- The low-level/harvest float must be mounted to the side of the water trough.
- The wire connectors for each float are different colors to eliminate any confusion during reassembly.  
**Blue = Low-Level/Harvest Float Switch**  
**Red = High-Level/Ice Thickness Float Switch**

WIRE CONNECTORS ARE LOCATED BEHIND BULKHEAD

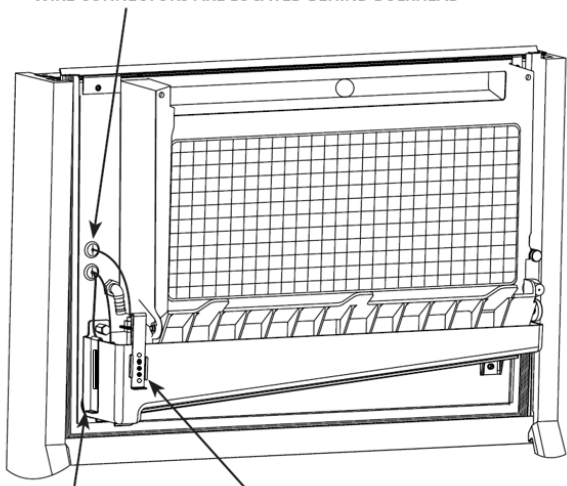

Low-Level/Harvest  
Float Switch & Bracket

High-Level/Ice Thickness  
Float Switch & Bracket

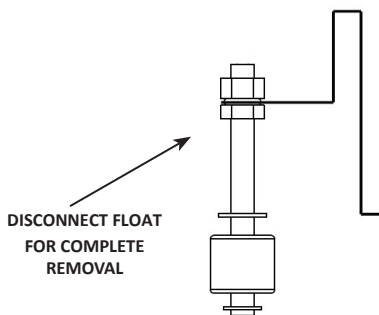

**⚠ Caution**

Do not disassemble float for descaling - Incorrect reassembly will result in an ice machine that will not harvest.

2. Remove the Slush Thermistor and Water Trough

- Remove the screw from on top of the slush thermistor that is holding it to the top of the water trough.
- Remove the slush thermistor.
- While supporting the water trough remove the upper and lower thumbscrews from the water trough.
- Remove the water trough from the bin area.

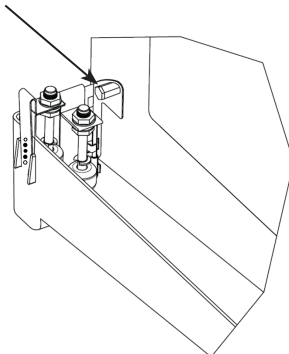
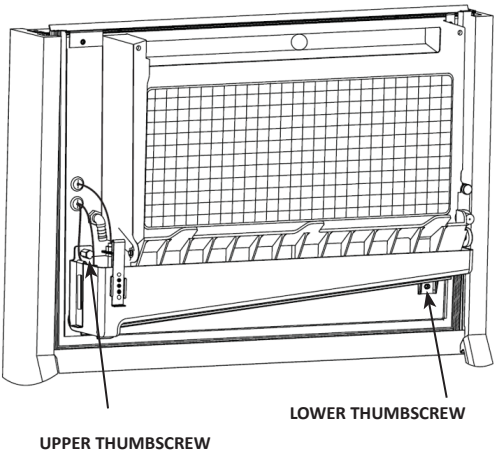

3. Remove the Ice Damper

- Remove thumbscrew from bin switch cover.
- Support ice damper and then pull bin switch cover and ice damper forward to remove.

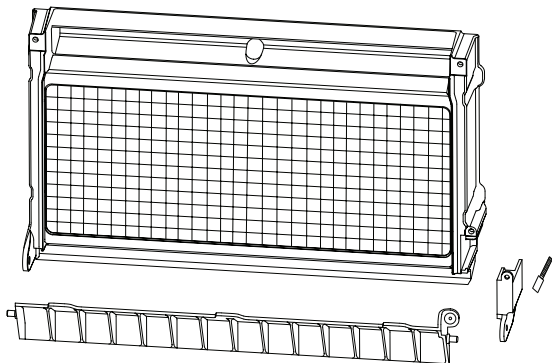

**1. REMOVE THUMBSCREW**

**2. SUPPORT ICE DAMPER THEN  
SLIDE RIGHT SIDE FORWARD TO REMOVE**

#### 4. Remove the Water Distribution Tube

- Remove thumbscrews from the left and right of distribution tube.
- Pull forward on the distribution tube to release.

NOTE: For ease of assembly when reinstalling the water distribution tube, install the top edge first.

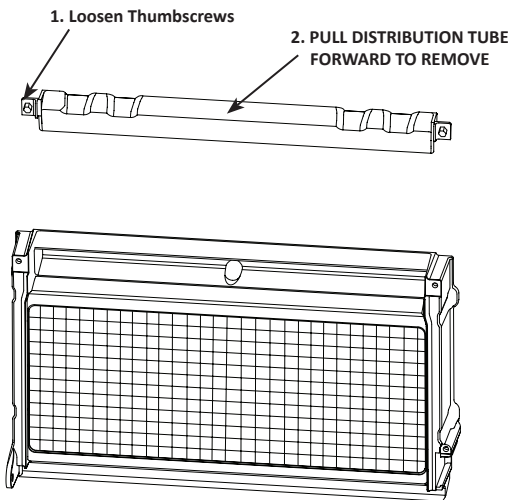

## **Ice Machine Inspection**

Check all water fittings and lines for leaks. Also, make sure the refrigeration tubing is not rubbing or vibrating against other tubing, panels, etc.

Do not put anything (boxes, etc.) in front of the ice machine. There must be adequate airflow through and around the ice machine to maximize ice production and ensure long component life.

## **Exterior Cleaning**

Clean the area around the ice machine as often as necessary to maintain cleanliness and efficient operation.

Sponge any dust and dirt off the outside of the ice machine with mild soap and water. Wipe dry with a clean, soft cloth.

Cleanup any fallen ice or water spills as they occur.

## CLEANING THE CONDENSER

### General

#### **Warning**

Disconnect electrical power to the ice machine at the disconnect/breaker box before cleaning the condenser.

A dirty condenser restricts airflow, resulting in excessively high operating temperatures. This reduces ice production and shortens component life.

- Clean the condenser at least every six months.

#### **Warning**

The condenser fins are sharp. Use care when cleaning them.

- Shine a flashlight through the condenser to check for dirt between the fins.
- Blow compressed air or rinse with water from the inside out (opposite direction of airflow).

NOTE: Cleaning the condenser will require the removal of the bin on some models.

## **REMOVAL FROM SERVICE/WINTERIZATION**

### **Self-contained Air-cooled ice machines**

1. Descale and sanitize the ice machine.
2. Set the 'ICE/OFF/WASH' switch to the 'OFF' position.
3. Turn off the water supply, disconnect and drain the incoming ice-making water line at the rear of the ice machine and drain the water trough.
4. Energize the ice machine, wait o for the water inlet valve to open, and blow compressed air into the incoming water openings in the rear of the ice machine to remove all water.
5. Set the 'ICE/OFF/WASH' switch to 'OFF' and disconnect the electric power at the circuit breaker or the electric service switch.
6. Fill spray bottle with sanitizer and spray all interior food zone surfaces. Do not rinse and allow to air dry.
7. Replace all panels.

## BIN REMOVAL - OLD MODELS

IC-0170/IU-0170/IC-0220/IU-0220

1. Disconnect power.
2. Remove all ice from bin.
3. Remove air filter and louver from lower front of machine.
4. Loosen screws and rotate clips to release bin from base.
5. Disconnect clamp and remove bin drain.
6. Remove communication cable from control board.
7. Remove top cover.
8. Slide bin forward to remove.

NOTE: When reinstalling the bin, ensure the bin seal is in place and is not pinched/folded as it mates to the cabinet. A watertight seal is required to prevent future condensation or water leakage from entering the ice machine base.

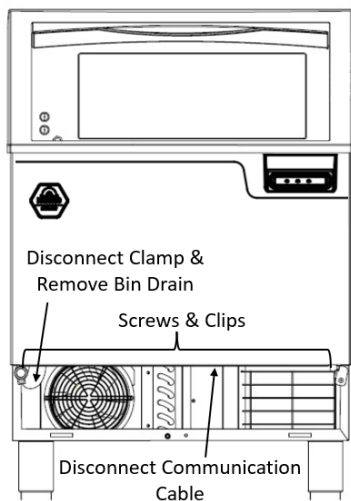

## BIN REMOVAL - NEW MODELS

IU-0170 & IU-0220

1. Disconnect power.
2. Remove all ice from bin.
3. Remove air filter and louver from lower front of machine.
4. Remove screws from the left & right side of the ice machine.
5. Disconnect clamp and remove bin drain.
6. Remove communication cable from control box.
7. Remove top cover.
8. Slide bin forward to remove.

NOTE: When reinstalling the bin, ensure the bin seal is in place and is not pinched/folded as it mates to the cabinet. A watertight seal is required to prevent future condensation or water leakage from entering the ice machine base.

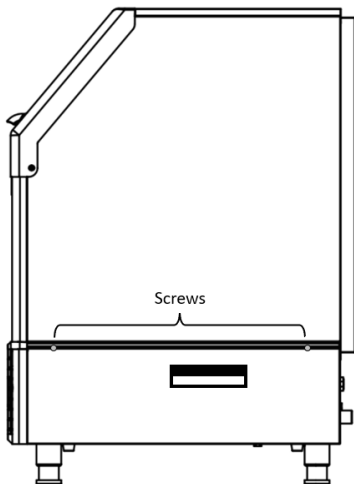

## Detailed Descaling and Sanitizing Procedure WU-0100

Ice machine cleaner is used to remove lime scale and mineral deposits. Ice machine sanitizer disinfects and removes algae and slime.

**Step 1** Set the 'ICE/OFF/WASH' switch to 'OFF' and wait for the ice machine to stop after the harvest cycle ends and ice falls from the evaporator.

### **Caution**

Never use anything to force ice from the evaporator. Damage may result.

**Step 2** Remove all ice from the bin.

### **Warning**

Wear rubber gloves and safety goggles (and/or face shield) when handling Ice Machine Cleaner or Sanitizer.

### **Caution**

Do not mix Ice Machine Cleaner and Sanitizer solutions together. It is a violation of Federal law to use these solutions in a manner inconsistent with their labeling.

**Step 3** To start the cycle set the 'ICE/OFF/WASH' switch to 'WASH'.

**Step 4** Wait until water flows over the evaporator then add the proper amount of Nickle Safe Ice Machine Cleaner to the water trough.

Model	Amount of Cleaner/Descaler Part Number 9405463
WU-0100	1.5 ounces (45 ml)

**Step 5** Wait until the cycle is complete (approximately 21 minutes) then place the 'ICE/OFF/WASH' switch in the 'OFF' position and disconnect power and water supplies to the ice machine.

**⚠ Warning**

Disconnect electric power to the ice machine at the electric switch box before proceeding.

**Step 6** Remove parts for descaling.

- A. Loosen the two screws securing the pump mounting bracket to the right-side bulkhead.
- B. Disconnect the water pump power cord behind the rear bulkhead and pull it through.
- C. Remove the vinyl hose connecting the water pump and water distribution tube.
- D. Lift up on the water pump and remove it.

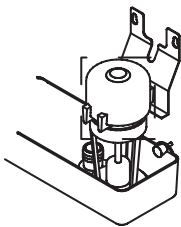

D. Remove the Ice Thickness Probe

- Compress the side of the ice thickness probe near the top hinge pin and remove it from the bracket.

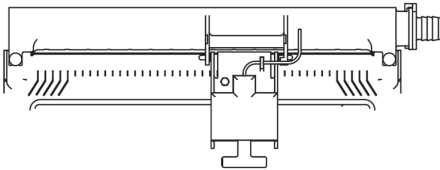

NOTE: At this point, the ice thickness probe can easily be descaled. If complete removal is desired disconnect the ice thickness probe wire behind the rear bulkhead.

### Ice Thickness Probe Descaling

- Mix a solution of nickle safe ice machine cleaner and water (2 ounces of cleaner to 16 ounces of water) in a container.
- Soak the ice thickness probe a minimum of 10 minutes.

Descal all ice thickness probe surfaces and verify the ice thickness probe cavity is descaled. Rinse thoroughly with clean water, then dry completely. Incomplete rinsing and drying of the ice thickness probe can cause premature harvest.

E. Remove the Water Distribution Tube

- Loosen the two thumbscrews, which secure the distribution tube.
- Lift the distribution tube up off the thumbscrews.

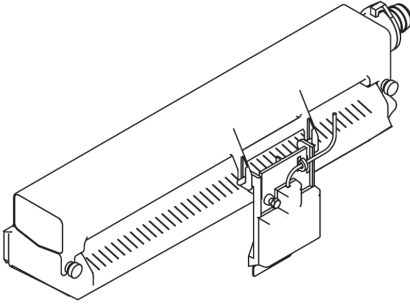

Disassembly

- Twist the barbed end until the tab lines up with the key way.
- Pull the inner tube end outward

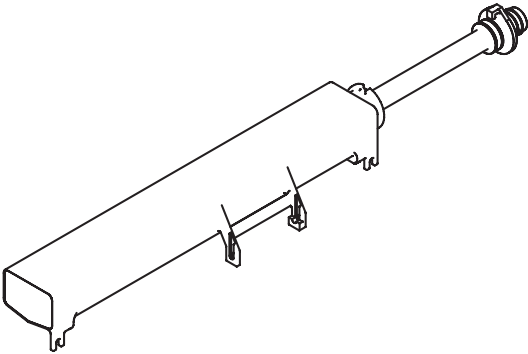

#### F. Remove the Float Valve

- Disconnect the water inlet tube from the float valve at the JG fitting by pushing down on the collar and lifting up on the tubing.
- Loosen the two screws holding the float assembly to the read bulkhead.
- Lift up on the the float assembly and pull it forward to remove it.

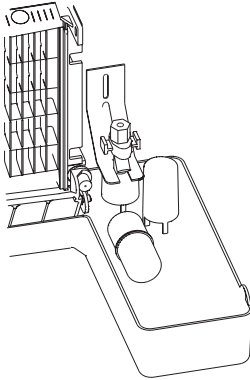

### G. Remove the Water Trough

- Apply downward pressure on the siphon tube and remove from the bottom of the water trough.
- Remove the upper thumbscrew.
- While supporting the water trough remove the two thumbscrews from beneath the water trough.
- Remove the water trough from the bin area.

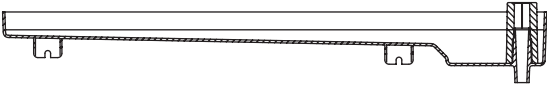
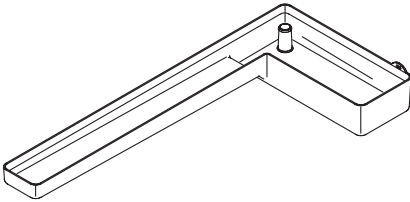

H. Remove the ice damper.

- Grasp left side of ice damper and apply pressure against the right-hand ice damper mounting bracket.
- Pull forward on the ice damper until the left hand mounting pin disengages.

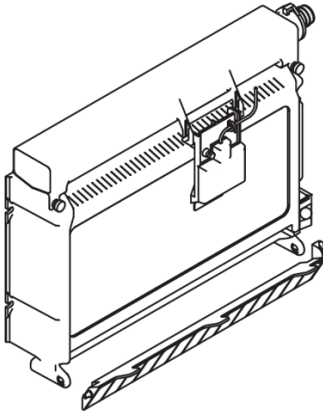

#### Installation

- Grasp the right side of ice damper and place left hand pin in the mounting bracket.
- While applying pressure against the left-hand mounting bracket push the damper up until the right-hand mounting pin engages.

Note: The right-hand mounting pin is notched. Please ensure the notched end of the pin is facing the direction you are pushing.

## I. Remove the Bin Door

- With the door open, slide the pins on the right-hand side of bin door to the left and pull down until the right-hand side disengages the track.
- While supporting the door, allow the right-hand side of the door to naturally fall into the bin and the left-hand side of the door will disengage the track.
- Remove the door from inside of the machine.

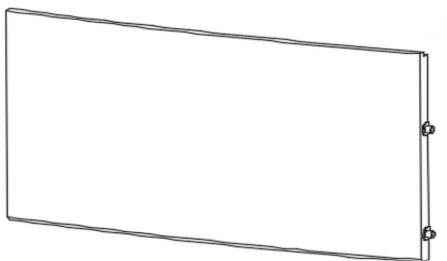

**Step 7** Mix a solution of cleaner and warm water. Depending on the amount of mineral buildup, a larger quantity of solution may be required. Use the ratio in the table below to mix enough solution to thoroughly descale all parts.

Solution Type	Water	Mixed with
Cleaner	1 gal. (4 l)	16 oz (500 ml) cleaner

**Step 8** Use ½ of the cleaner/descaler and water solution to descale all components. The solution will foam when it contacts lime scale and mineral deposits; once the foaming stops use a soft bristle brush, sponge or cloth (not a wire brush) to carefully descale the parts. Soak the parts for 5 minutes (15 – 20 minutes for heavily scaled parts). Rinse all components with clean water.

**Step 9** While components are soaking, use ½ of the cleaner/descaler and water solution to descale all foodzone surfaces of the ice machine and bin. Use a nylon brush or cloth to thoroughly descale the following ice machine areas:

- Evaporator plastic parts – including top, bottom and sides.
- Bin bottom, sides and top.
- Rinse all areas thoroughly with clean water.

**Step 10** Mix a solution of sanitizer and warm water.

Solution Type	Water	Mixed With
Sanitizer	1 gal. (23 l)	4 oz (120 ml) sanitizer

**Step 11** Use 1/2 of the sanitizer/water solution to sanitize all removed components. Use a cloth or sponge to liberally apply the solution to all surfaces of the removed parts or soak the removed parts in the sanitizer/water solution. Do not rinse parts after sanitizing.

**Step 12** Use 1/2 of the sanitizer/water solution to sanitize all foodzone surfaces of the ice machine and bin. Use a cloth or sponge to liberally apply the solution. When sanitizing, pay particular attention to the following areas:

- Evaporator plastic parts - including top, bottom and sides.
- Bin bottom, sides and top.

Do not rinse the sanitized areas.

**Step 13** Replace all removed components.

**Step 14** Reapply power and water to the ice machine and place the toggle switch in the WASH position.

**Step 15** Add the proper amount of Ice Machine Sanitizer to the water trough.

Model	Amount of Sanitizer
WU-0100	1.5 ounces (45 ml)

**Step 16** Wait until the sanitize cycle is complete (approximately 21 minutes) then place the 'ICE/OFF/WASH' switch in the 'OFF' position, disconnect power and water supplies to the ice machine.

** Warning**

Disconnect electric power to the ice machine at the electric switch box before proceeding.

**Step 17** Repeat step 6 to remove parts for hand sanitizing.

**Step 18** Mix a solution of sanitizer and warm water.

Solution Type	Water	Mixed With
Sanitizer	1 gal. (23 l)	4 oz (120 ml) sanitizer

**Step 19** Use 1/2 of the sanitizer/water solution to sanitize all removed components. Use a cloth or sponge to liberally apply the solution to all surfaces of the removed parts or soak the removed parts in the sanitizer/water solution. Do not rinse parts after sanitizing.

**Step 20** Use 1/2 of the sanitizer/water solution to sanitize all foodzone surfaces of the ice machine and bin. Use a cloth or sponge to liberally apply the solution. When sanitizing, pay particular attention to the following areas:

- Evaporator plastic parts - including top, bottom and sides
- Bin bottom, sides and top

Do not rinse the sanitized areas.

**Step 21** Replace all removed components.

**Step 22** Reapply power and water to the ice machine and place the 'ICE/OFF/WASH' switch in the 'ICE' position.

## **CLEANING THE CONDENSER**

A dirty condenser restricts airflow, resulting in excessively high operating temperatures. This reduces ice production and shortens component life. Clean the condenser at least every six months. Follow the steps below.

1. The washable filter on self-contained ice machines is designed to catch dust, dirt, lint and grease. This helps keep the condenser clean. Clean the filter with a mild soap and water solution.
2. Clean the outside of the condenser with a soft brush or a vacuum with a brush attachment. Clean from top to bottom, not side to side. Be careful not to bend the condenser fins.
3. Shine a flashlight through the condenser to check for dirt between the fins. If dirt remains: Blow compressed air through the condenser fins from the inside. Be careful not to bend the fan blades.
4. Use a commercial condenser coil cleaner. Follow the directions and cautions supplied with the cleaner.
5. Straighten any bent condenser fins with a fin comb.
6. Carefully wipe off the fan blades and motor with a soft cloth. Do not bend the fan blades. If the fan blades are excessively dirty, wash with warm, soapy water and rinse thoroughly.

## **REMOVAL FROM SERVICE/WINTERIZATION**

### **Self-contained Air-cooled ice machines**

Special precautions must be taken if the ice machine is to be removed from service for an extended period of time or exposed to ambient temperatures of 32°F (00C) or below.

1. Disconnect the electric power at the circuit breaker or the electric service switch.
2. Turn off the water supply.
3. Remove the water from the water trough.
4. Disconnect the drain and the incoming ice-making water line at the rear of the ice machine.
5. Make sure no water is trapped inside the ice machine's incoming water line, drain line, distribution tube, etc.

# Operation

---

## Sequence of Operation

IC-0170/IU-0170/IC-0220/IU-0220

### MAIN POWER SWITCH

The 'ICE/OFF/WASH' switch is located on the front of the machine, toward the lower right-hand side.

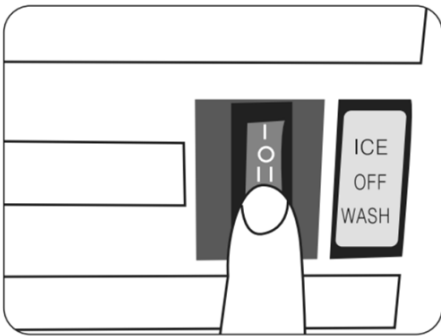

### Powering the machine on and off

The 'ICE/OFF/WASH' switch is used to start and stop ice making. Moving the switch from 'OFF' to 'ICE' will initiate the ice making cycle.

NOTE: Stopping the ice machine by moving the 'ICE/OFF/WASH' switch to the 'OFF' position, will not immediately stop the machine. The current freeze/harvest cycle will have to finish before the ice machine completely stops operation.

## **Entering a wash cycle**

Placing the switch in the 'WASH' position will initiate the cleaning cycle.

NOTE: Once a cleaning cycle has begun, the machine will not make ice until the cleaning cycle is completed (approximately 21 minutes). Additionally, once the cleaning cycle has finished, all operation will stop and the 'ICE/OFF/WASH' switch must be placed back to the 'ICE' position for the machine to resume ice making.

## **Bin Full**

The 'FULL' light energizes when the bin is full or is de-energized if the bin is not full. Additionally, the 'FULL' light will flash when there is a was supply issue.

## **Error**

The 'ERROR' light indicates the machine needs attention and will light up, or flash together with the 'POWER' light, when there is a problem.

- Refer to "Error Codes" on page 61 if this light is energized.

## **SEQUENCE OF OPERATION**

The 'ICE/OFF/WASH' switch must be in the 'ICE' position and the ice damper must be closed before the ice machine will start.

The following is the primary sequence of operation.

### **Initial Start-Up or Start-Up After Automatic Shutdown**

#### **1. Water Flush**

The dump valve is energized to discard any remaining water in the water trough for 22 seconds.

#### **2. Pressure Equalization**

At the same time that the dump valve is energized, the hot gas valve also energizes for 28 seconds to allow for pressure equalization and to reduce compressor starting torque.

### **Freeze Sequence**

#### **3. Prechill**

After the 28 second equalization, the dump valve de-energizes and the compressor and condenser fan motor energize and run for approximately 2 minutes, with no water circulation, to lower the temperature of the evaporator before the water pump is energized.

NOTE: The fan motor is wired through a fan cycle pressure control and will not cycle on until/unless the compressor is running.

#### **4. Water Fill**

At the same time that the compressor & condenser fan motor are energized, the water inlet valve also energizes to allow water to fill the water trough, until the float switch(s) is satisfied.

## 5. Water Pump

Once both float switches are satisfied, the water pump energizes and water flows over the evaporator.

### Slush Thermistor

When the temperature of the water reaches 34°F the water pump de-energizes for approximately 15 seconds.

When the water pump energizes again, the water inlet valve also energizes to fill the water trough with fresh water for approximately 5 seconds.

**Note:** If water in trough continues to slush 2.5 minutes into the freeze cycle, set dip switch 5 on the PCB to the "ON" position.

**Dual Floats (Prior to TB Serial Numbers)** The freeze cycle continues until the water drops below the high-level/ice thickness float switch & low-level harvest float switch, closing them both for approximately 7 seconds, which initiates the harvest cycle.

### Ice Thickness Probe (On or After TB Serial Numbers )

The freeze cycle continues until water touches the ice thickness sensor for 7 continuous seconds, which initiates the harvest cycle.

## Harvest Sequence

### 5. Harvest

With the water pump de-energized, the dump valve and hot gas valve are energized. The refrigerant gas warms the evaporator causing the cubes to slide, as a sheet, off the evaporator and into the storage bin.

After a 30 second water purge, the dump valve is de-energized and the water inlet valve is energized to fill the water trough until the float switch(s) are satisfied.

The sliding sheet of cubes opens the ice damper and bin switch.

The momentary opening and re-closing of the bin switch terminates the harvest sequence and returns the ice machine to the freeze sequence.

NOTE: The maximum harvest time is 5 minutes. If the bin switch does not activate within 5 minutes, 3 consecutive times, the machine will stop and the power light will flash.

## **Automatic Shut-Off**

### **7. Automatic Shut-Off**

When the storage bin is full at the end of a harvest sequence, the sheet of cubes fails to clear the ice damper and will hold it open. After the ice damper is held open for 7 seconds, the ice machine shuts off.

The ice machine remains off until enough ice has been removed from the storage bin to allow the ice to clear the ice damper. As the ice damper swings back to the closed position, the bin switch closes and the ice machine restarts ( beginning with step 1).

**IC-0170/IU-0170/IC-0220/IU-0220 ENERGIZED PARTS CHART**

<b>Ice Making Sequence of Operation</b>	<b>Water Pump</b>	<b>Hot Gas Valve</b>	<b>Water Inlet Valve</b>	<b>Water Dump Valve</b>	<b>Compressor</b>	<b>Condenser</b>	<b>Approximate Length of Time</b>
<b>Start-Up</b>							
1. Water Flush	Off	On	Off	On	Off	Off	22 Seconds
2. Pressure Equalization	Off	On	Off	Off	Off	Off	27 Seconds
3. Compressor Startup	Off	On	Off	Off	On	On	5 Seconds
<b>Freeze Sequence</b>							
4. Prechill	Off	Off	On	Off	On	On	2 Minutes

Ice Making Sequence of Operation	Water Pump	Hot Gas Valve	Water Inlet Valve	Water Dump Valve	Compressor	Condenser	Approximate Length of Time
5. Water Fill	Off	Off	On	Off	On	On	Until Float(s) Satisfied
8. Freeze	On	Off	Off	Off	On	On	Until Floats or Ice Thickness Probe Satisfied
<b>Harvest Sequence</b> 9. Harvest	Off	On	Off	Off	On	Off	Bin Switch Activation
10. Water Flush	Off	On	Off	On	On	On	5 Seconds
11. Water Fill	Off	Off	On	Off	On	On	Until Float(s) Satisfied
12. Automatic Shut-Off	Off	Off	Off	Off	Off	Off	Until 3 Minute Delay Expires and Bin Switch Re-closes

## **ERROR CODES**

Error codes are stored by the control board and indicated by the LED lights on the front of the machine. The number of cycles required to stop the ice machine varies for each error code.

Error codes can be reset by cycling the 'ICE/OFF/WASH' switch between 'OFF' and 'ICE' and starting a new ice making cycle.

It is recommended that you first record the error code indicated on the machine before resetting it.

Continue to next page to see error codes



### POWER indicator (green)

- Lights up solid when power is supplied to the machine.

- **POWER indicator flashes**

1. Water Supply Issue: High-level float does not detect water within 5 minutes of the water inlet valve being energized.
2. Extended Freeze: Freeze time exceeds 65 minutes.
3. Extended Harvest: Harvest time exceeds 5 minutes, 3 consecutive times.

### FULL indicator (yellow)

- Lights up solid when the ice bin is full.

- **FULL indicator flashes**

1. Water Supply Issue: High-level float detects water 10 minutes sooner than the low-level float.

### ERROR indicator (red)

- Lights up solid or flashes together with POWER indicator when there is an issue.

- **POWER (green) flashes & ERROR (red) is solid:** High pressure switch is open for more than 10 seconds
- **POWER (green) flashes & ERROR (red) flashes:** High pressure switch is open for more than 10 seconds, 3 consecutive times.

## TROUBLESHOOTING ERROR CODES

Error codes are designed to notify the technician of a problem and, in some cases, stop the ice machine prior to a major component failure. This may be difficult to diagnose, as many external problems occur intermittently.

The following checklists are designed to assist the service technician in analysis. However, because there are many possible external problems, do not limit your diagnosis to only the items listed.

### ERROR CODE

#### ***POWER indicator (green) flashing:***

- 1. Water Supply Issue: High-level float does not detect water within 5 minutes of the water inlet valve being energized.***
- 2. Extended Freeze: Freeze time exceeds 65 minutes.***
- 3. Extended Harvest: Harvest time exceeds minutes, 3 consecutive times.***

#### *Possible cause checklist*

- Check that incoming water supply is on.
- Check that water pressure is not below 20 psi.
- Check that high-level float is operating properly.
- Check that dump valve is not stuck open.
- Check that the air filter or condenser is not dirty.
- Check that the ambient air temp is below 100°F.
- Check that there are no restrictions to air flow.
- Check that discharge air is not being recirculated.
- Check the refrigerant charge.
- Check the expansion valve.
- Clean the evaporator.
- Check the hot gas valve is operating properly.

## ERROR CODE

### ***FULL indicator (yellow) flashing:***

1. ***Water Supply Issue: High-level float detects water 10 minutes sooner than the low-level float.***

#### *Possible cause checklist*

- Check that the float(s) are properly installed.
- Check that the float(s) are working properly.
- Check all wire connections between the float(s) and the control board (PCB).

## ERROR CODE

### ***ERROR indicator (red) flashing:***

1. ***High Pressure Issue: High pressure switch open for more than 10 seconds.***
2. ***High Pressure Issue: High pressure switch open for more than 10 seconds, 3 consecutive times.***

#### *Possible cause checklist*

- Check that the air filter or condenser is not dirty.
- Check that the ambient air temp is below 100°F.
- Check that there are no restrictions to air flow.
- Check that discharge air is not being recirculated.
- Check the refrigerant charge.
- Check that the hot gas valve is working properly.

## Operational Checks

### ICE THICKNESS CHECK (FLOAT SWITCH)

After a harvest cycle, inspect the ice cubes in the ice storage bin. The ice bridge connects the ice cubes and must be set to maintain an ice bridge thickness of 1/8" (3.2 mm). To adjust the thickness of the bridge refer to ice thickness adjustment.

### ICE THICKNESS ADJUSTMENT

The ice thickness can be adjusted by moving the high-level/harvest float, on the front of the water trough, up or down.

1. Pull forward on the bottom of the bracket until clear of the tabs.
2. Slide the bracket over the desired tabs and release.
  - The center position is the normal factory setting.
  - To increase bridge thickness, raise the water level by moving the float up.
  - To decrease bridge thickness, lower the water level by moving the float down.

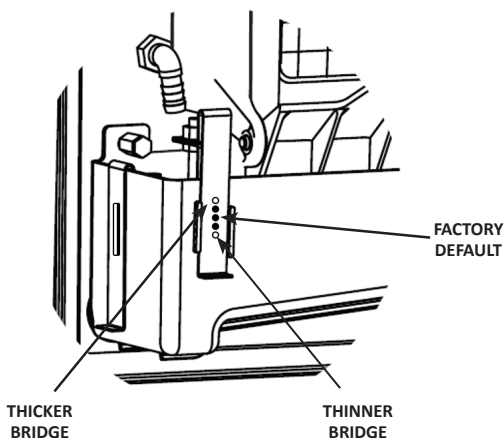

# Operational Checks

## ICE THICKNESS CHECK (ICE THICKNESS PROBE)

After a harvest cycle, inspect the ice cubes in the ice storage bin. The ice bridge connects the ice cubes and must be set to maintain an ice bridge thickness of 1/8" (3.2 mm). To adjust the thickness of the bridge refer to ice thickness adjustment.

## ICE THICKNESS ADJUSTMENT

The ice thickness can be adjusted by turning the adjustment screw on the ice thickness control.

1. If adjustment is necessary, turn the ice thickness probe adjustment screw clockwise to increase bridge thickness or counterclockwise to decrease bridge thickness. Set a 1/4" gap between the ice thickness probe and evaporator as a starting point. Then adjust to achieve 1/8" ice thickness.
2. Make sure the ice thickness probe wire and the bracket do not restrict movement of the probe.

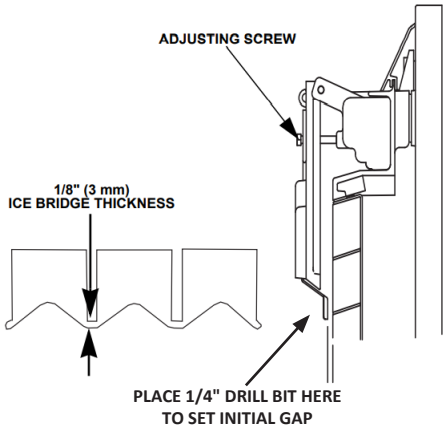

**NOTE:** Machines using an ice thickness probe should have dip switch 8 on the PCB in the "ON" position.

**MINIMUM/MAXIMUM SLAB WEIGHT**

<b>Model</b>	<b>Minimum Ice Weight Per Cycle lbs Grams</b>	<b>Maximum Ice Weight Per Cycle lbs Grams</b>
IC-0170	2.26 lbs 1025 grams	2.93 lbs 1329 grams
IU-0170	2.26 lbs 1025 grams	2.93 lbs 1329 grams
IC-0220	2.26 lbs 1025 grams	2.93 lbs 1329 grams
IU-0220	2.26 lbs 1025 grams	2.93 lbs 1329 grams

## Sequence of Operation WU-0100

### Initial start-up or start-up after automatic shut-off

#### 1. Pressure Equalization

Before the compressor starts the hot gas valve is energized for 15 seconds to equalize pressures during the initial refrigeration system start-up.

#### 2. Refrigeration System Start-up

The compressor is energized after the 15-second pressure equalization, and remains on throughout the entire Freeze and Harvest Sequences. The hot gas valve remains on for 5 seconds during initial compressor start-up and then shuts off. At the same time the compressor starts, the condenser fan motor is energized throughout the entire Freeze Sequence.

#### 3. Prechill

The compressor is on for 30 seconds prior to water flow to prechill the evaporator.

#### 4. Freeze

The water pump starts after the 30-second prechill. An even flow of water is directed across the evaporator and into each cube cell, where it freezes. When sufficient ice has formed, water contacts the ice thickness probe. After approximately 5 seconds of continual water contact, the Harvest Sequence is initiated.

## 5. Harvest

The water pump de-energizes stopping flow over the evaporator. The rising level of water in the sump trough diverts water out of the overflow tube, purging excess minerals from the sump trough. The hot gas valve also opens to divert hot refrigerant gas into the evaporator. The refrigerant gas warms the evaporator causing the cubes to slide, as a sheet, off the evaporator and into the storage bin. The sliding sheet of cubes contacts the ice damper, opening the bin switch. The momentary opening and re-closing of the bin switch terminates the harvest cycle and returns the ice machine to freeze (steps 3 - 4).

## 6. Automatic Shut-off

When the storage bin is full at the end of a harvest sequence, the sheet of cubes fails to clear the ice damper and will hold it down. After the ice damper is held open for 7 seconds, the ice machine shuts off. The ice machine remains off for 3 minutes before it can automatically restart. The ice machine remains off until enough ice has been removed from the storage bin to allow the ice to fall clear of the damper. As the ice damper swings back to the operating position, the bin switch re-closes and the ice machine restarts (steps 1 - 2), provided the 3 minute delay period is complete.

## WU-0100 ENERGIZED PARTS CHART

ICE MAKING SEQUENCE OF OPERATION	Control Board Relays				Length of Time
	Water Pump	Hot Gas Valve	Compressor	Condenser Fan Motor	
Initial Start-up 1. Pressure Equalization	Off	On	Off	Off	15 seconds
2. Refrigeration System Start-up	Off	On	On	On	5 seconds
Freeze Sequence 3. Prechill	Off	Off	On	On	30 seconds
4. Freeze	On	Off	On	On	Until 5 sec. Water contact w/ice thickness probe
Harvest Sequence 5. Harvest	Off	On	On	Off	Bin switch activation

ICE MAKING SEQUENCE OF OPERATION	Control Board Relays				Length of Time
	Water Pump	Hot Gas Valve	Compressor	Condenser Fan Motor	
Automatic Shut-off 6. Auto Shut-off	Off	Off	Off	Off	Until bin switch re-closes

## Operational Checks WU-0100

### SIPHON SYSTEM

To reduce mineral build-up and cleaning frequency, the water in the sump trough must be purged during each harvest cycle.

When the water pump de-energizes the level in the water trough rises above the standpipe starting a siphon action. The siphon action stops when the water level in the sump trough drops. When the siphon action stops, the float valve refills the water trough to the correct level.

Follow steps 1 through 6 under water level check to verify the siphon system functions correctly.

### WATER LEVEL

Check the water level while the ice machine is in the ice mode and the water pump is running. The correct water level is 1/4" (6.3 mm) to 3/8" (9.5 mm) below the top of the standpipe.

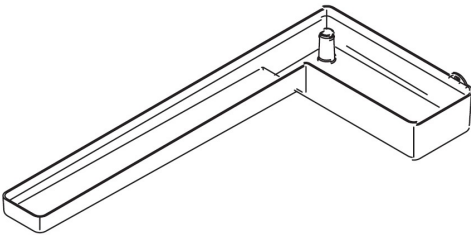

## **WATER LEVEL CHECK**

The float valve is factory-set for the proper water level.

If adjustments are necessary:

1. Verify the ice machine is level.
2. Place the main 'ICE/OFF/WASH' switch to the 'ON' position, and wait until the float valve stops adding water.
3. Adjust the water level to 1/4" to 3/8" (6.3 to 9.5 mm) below the standpipe:
  - A. Loosen the two screws on the float valve bracket.
  - B. Raise or lower the float valve assembly as necessary, then tighten the screws.
  - C. Move the main 'ICE/OFF/WASH' toggle switch to the 'OFF' position. The water level in the trough will rise above the standpipe and run down the drain.

## ICE THICKNESS CHECK

After a harvest cycle, inspect the ice cubes in the ice storage bin. The ice thickness probe is set to maintain an ice bridge of 1/8" (3.2 mm). If an adjustment is needed, follow the steps below.

1. Turn the ice thickness probe adjustment screw clockwise for a thicker ice bridge, or counterclockwise for a thinner ice bridge.
2. Make sure the ice thickness probe wire and bracket does not restrict movement of the probe.

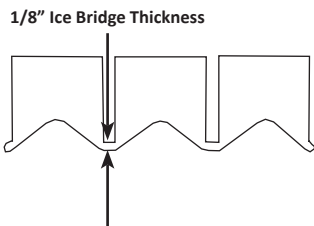
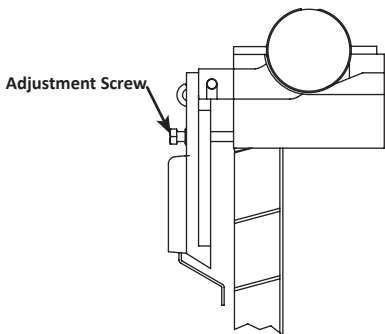

# Troubleshooting

## Troubleshooting

### IC-0170/IU-0170/IC-0220/IU-0220

NOTE: Refer to “Troubleshooting WU-0100” on page 106 for that model.

#### PROBLEM CHECKLIST

Problem	Possible Cause	Correction
Ice machine does not operate	No electrical power to the ice machine.	Replace the fuse/reset the breaker/turn on the main switch/plug power cord into receptacle.
	Ice machine needs to be turned on.	Turn 'ICE/OFF/WASH' switch to 'ICE'.
	Damper in open position (down).	Damper must be in upright position and capable of swinging freely.
Ice machine stops, and can be restarted by turning the ice machine OFF/ ON.	Error Code stopping the ice machine..	Refer to “Error Codes”
Ice sheet is thick	Water trough level is too high.	Adjust ice thickness float.
	Ice damper was opened then closed in the harvest cycle before the ice released.	Allow ice to thaw and release from evaporator, then restart
	Ice thickness probe is out of adjustment	Adjust ice thickness probe.
Ice machine does not release ice or is slow to harvest.	Ice machine is dirty.	Descale and sanitize the ice machine
	Ice machine is not level.	Level the ice machine
	Low air temperature around ice machine	Air temperature must be at least 50° F (10°C).

<b>Problem</b>	<b>Possible Cause</b>	<b>Correction</b>
Ice machine does not cycle into harvest mode.	Harvest float switch is dirty.	Descale and sanitize the ice machine.
	Harvest float switch wire is disconnected.	Connect the wire
	Harvest float switch is out of adjustment.	Adjust the harvest float switch.
	Ice thickness probe out of adjustment or dirty	Adjust or clean the ice thickness probe.
	Uneven ice fill (thin at top of evaporator).	Refer to "Shallow or Incomplete Cubes"
Ice quality is poor	Poor incoming water quality.	Test the quality of the incoming water and make appropriate filter recommendations.
	Water filtration is poor.	Replace the filter.
	Ice machine is dirty.	Descale and sanitize the ice machine.
Ice machine produces shallow or incomplete cubes, or the ice fill pattern on the evaporator is incomplete.	Ice thickness probe out of adjustment or dirty	Adjust or clean the ice thickness probe.
	Ice thickness float is out of adjustment.	Adjust the ice thickness float
	Water level is too low.	Check the water float.
	Water filtration is poor.	Replace the filter.
	Hot incoming water.	Connect the ice machine to a cold water supply.
	Incorrect incoming water pressure.	Water pressure must be 20-80 psi (137.9 -551.5 kPa)
	Ice machine is not level.	Level the ice machine
Low ice capacity.	The condenser is dirty.	Clean the condenser.
	High air temperature around ice machine (air-cooled models).	Air temperature must not exceed 100° F (43°C).
	Inadequate clearance around the ice machine.	Provide adequate clearance
	Objects stacked around ice machine, blocking condenser airflow	Remove items blocking airflow
	Hot incoming water.	Connect to cold water
	Incorrect incoming water pressure. Water pressure is too low or water filter is restricted.	Water pressure must be 20-80 psi (137.9 -551.5 kPa). Replace water filter.

## CONTROL BOARD (IC-0170/IU-0170/IC-0220/IU-0220)

### FUNCTION

The PCB is what controls the operation of all the major components within the ice machine. Each major component has a white relay above it's terminal connection on the PCB. Above that relay is a green light that will illuminate anytime power is being sent to that component. This, along with the sequence of operation, makes troubleshooting a breeze for the service technician, as a simple visual check to the PCB will indicate whether or not a specific component should be operating.

### STANDBY MODE

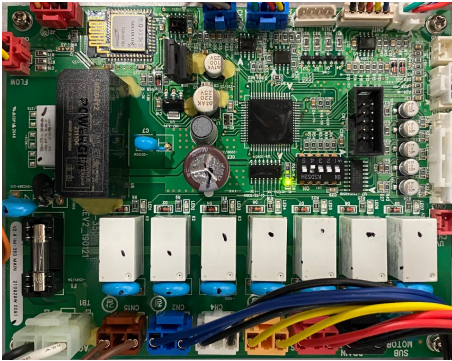

Only LED next to dipswitches lights up.

## CONTROL BOARD (PCB) Cont.

### FREEZE MODE: Sequence of Operation

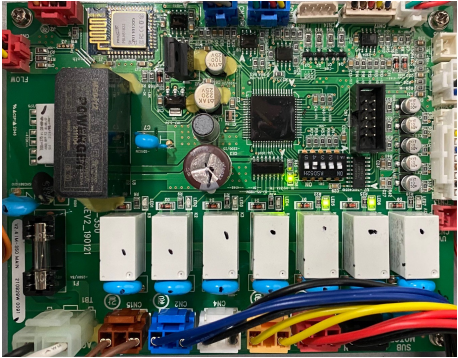

Dump valve (black) & hot gas valve (red) energized to flush water & equalize pressure.

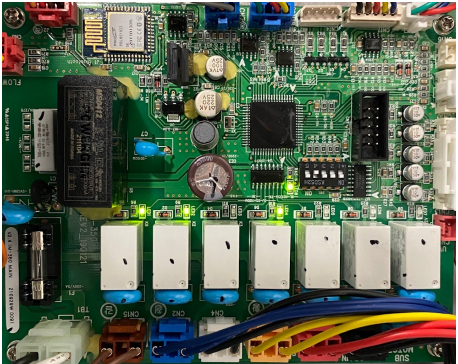

Compressor (brown), condenser (blue), & water inlet valve (yellow) energized for prechill & water fill.

## CONTROL BOARD (PCB) Cont.

### FREEZE MODE: Sequence of Operation

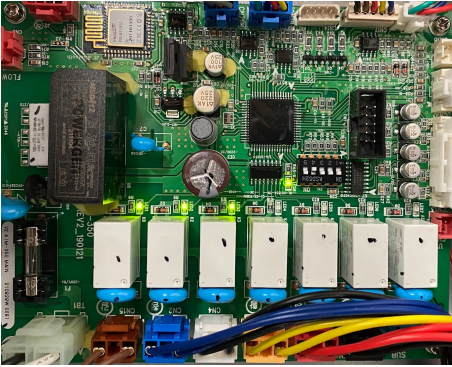

Compressor (brown), condenser (blue), water pump (white) energized to circulate & freeze water to evaporator.

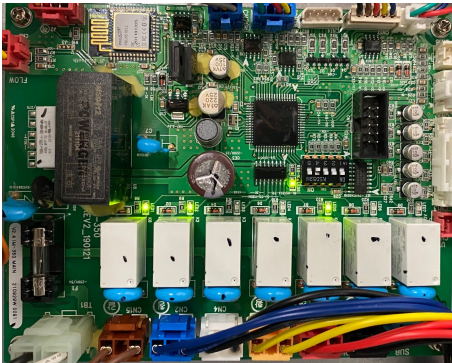

Compressor (brown), condenser (blue), & hot gas valve (red) energized for harvest.

## DIAGNOSING AN ICE MACHINE THAT WILL NOT RUN

### **Warning**

High (line) voltage is applied to the control board at all times. Removing the control board fuse or moving the 'ICE/OFF/WASH' switch to 'OFF' will not remove the power supplied to the control board.

1. Verify primary voltage is supplied to ice machine and the fuse/circuit breaker is closed.

2. Verify control board fuse is okay.

NOTE: If any control board lights are on, the fuse is okay.

3. Verify the bin switch functions properly. A defective bin switch can falsely indicate a full bin of ice.

4. Verify 'ICE/OFF/WASH' switch functions properly.

## **ICE MACHINE DOES NOT CYCLE INTO HARVEST WHEN THE HARVEST FLOAT IS DOWN/CLOSED**

### **(OLD MODELS)**

NOTE: The ice machine will make a thick or double slab when a new freeze cycle is started with ice already present on the evaporator.

#### **Two of the most common scenarios are:**

- The machine exceeds the 65 minute freeze time and enters into an automatic harvest, but the ice does not come off the plate.
- The ice damper/bin switch is opened/closed in the harvest cycle before the ice releases.

If the harvest float is suspected to be the problem, use the following procedure.

**Step 1** With the machine in the freeze cycle, use a jumper wire across the two (red) high-level float switch connectors and the two (blue) low-level float switch connectors, at the control box, to complete the two circuits. If after 5 seconds the machine goes into harvest, move to step 2

NOTE: If the machine continues in the freeze cycle, the control board is causing the malfunction.

**Step 2** Remove both float and test them for continuity. Refer to "Float Switch" on page 128.

## **ICE MACHINE DOES NOT CYCLE INTO HARVEST WHEN WATER TOUCHES THE ICE THICKNESS PROBE (NEW MODELS)**

NOTE: The ice machine will make a thick or double slab when a new freeze cycle is started with ice already present on the evaporator.

### **Two of the most common scenarios are:**

- The machine exceeds the 65 minute freeze time and enters into an automatic harvest, but the ice does not come off the plate.
- The ice damper/bin switch is opened/closed in the harvest cycle before the ice releases.

If the ice thickness probe is suspected to be the problem, use the following procedure.

Use a jumper wire between the (red) ice thickness connector at the control box and any cabinet ground. If after 5 seconds the machine goes into harvest, replace the probe. If the machine continues in the freeze cycle, the control board is causing the malfunction.

NOTE: If you suspect a defective probe, check the wire harness between the ice thickness probe & control board for continuity before replacing.

## ICE MACHINE CYCLES INTO HARVEST BEFORE THE HARVEST FLOAT IS DOWN/CLOSED

**Step 1** Disconnect power to the ice machine and remove the low-level/harvest float switch (blue) from its connector on the outside of the control box.

WIRE CONNECTORS ARE LOCATED BEHIND BULKHEAD

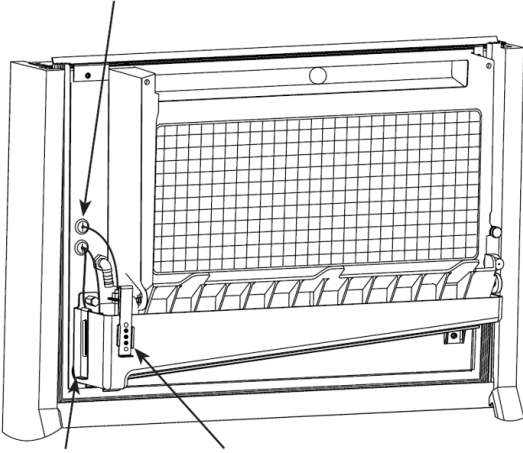

Low-Level/Harvest  
Float Switch & Bracket

High-Level/Ice Thickness  
Float Switch & Bracket

**Step 2** Reapply power and move the 'ICE/OFF/WASH' switch to the 'ICE' position. Wait until water flows over the evaporator, then refer to chart.

<b>Result</b>	<b>Correction</b>
The ice machine stays in freeze.	The ice thickness float switch, connectors or wiring is causing the malfunction.
The ice machine cycles from freeze to harvest.	Replace the control board.

## ICE PRODUCTION CHECK

The amount of ice a machine produces directly relates to the operating water and air temperatures. This means an ice machine with a 70°F (21°C) ambient temperature and 50°F (10°C) water produces more ice than the same ice machine with 90°F (32°C) ambient and 70°F (21°C) water.

- Determine the ice machine operating conditions:  
Air temp entering condenser: \_\_\_\_\_°  
Air temp around ice machine: \_\_\_\_\_°  
Water temp entering sump trough: \_\_\_\_\_°
- Refer to the appropriate "Cycle Times, 24 Hr. Ice Production and Refrigerant Pressure Charts" on page 219. Use the operating conditions determined in Step 1 to find published 24-Hour Ice Production: \_\_\_\_\_
  - Times are in minutes.  
Example: 1 min. 15 sec. converts to 1.25 min.  
(15 seconds ÷ 60 seconds = .25 minutes)
  - Weights are in pounds.  
Example: 2 lb. 6 oz. converts to 2.375 lb.  
(6 oz. ÷ 16 oz. = .375 lb.)
- Perform an ice production check using the formula below.

1.	$\frac{\text{Freeze Time}}{\text{Freeze Time}}$	+	$\frac{\text{Harvest Time}}{\text{Harvest Time}}$	=	$\frac{\text{Total Cycle Time}}{\text{Total Cycle Time}}$
2.	$\frac{1440}{\text{Minutes in 24 Hrs.}}$	÷	$\frac{\text{Total Cycle Time}}{\text{Total Cycle Time}}$	=	$\frac{\text{Cycles per Day}}{\text{Cycles per Day}}$
3.	$\frac{\text{Weight of One Harvest}}{\text{Weight of One Harvest}}$	x	$\frac{\text{Cycles per Day}}{\text{Cycles per Day}}$	=	$\frac{\text{Actual 24-Hour Production}}{\text{Actual 24-Hour Production}}$

4. Compare the results of step 3 with step 2. Ice production is normal when these numbers match closely. If they match closely, determine if:
  - Another larger ice machine is required.
  - Relocating the existing equipment to lower the load conditions is required.

Contact the local Icetec distributor for information on available options and accessories.

## INSTALLATION/VISUAL INSPECTION CHECKLIST

### ***Ice machine is not level***

- Level the ice machine

### ***Condenser is dirty***

- Clean the condenser

### ***Water filtration is plugged (if used)***

- Install a new water filter

### ***Water drains are not run separately and/or are not vented***

- Run and vent drains according to the Installation Manual

## WATER SYSTEM CHECKLIST

A water-related problem often causes the same symptoms as a refrigeration system component malfunction.

Example: A water dump valve leaking during the freeze cycle, a system low on charge, and a starving TXV have similar symptoms.

Water system problems must be identified and eliminated prior to replacing refrigeration components.

### ***Water area (evaporator) is dirty***

- Descale as needed

### ***Water inlet pressure not between 20 and 80 psig (1–5 bar, 138–552 kPa)***

- Install a water regulator valve or increase the water pressure

### ***Incoming water temperature is not between 50°F (10°C) and 90°F (32°C)***

- If too hot, check the hot water line check valves in other store equipment

### ***Water filtration is plugged (if used)***

- Install a new water filter

***Vent tube is not installed on water outlet drain***

- See Installation Instructions

***Hoses, fittings, etc., are leaking water***

- Repair/replace as needed

***Water valve is stuck open, closed or is leaking***

- Descale/replace as needed

***Water is spraying out of the sump trough area***

- Stop the water spray

***Uneven water flow across the evaporator***

- Descale the ice machine

***Water is freezing behind the evaporator***

- Correct the water flow

## ICE FORMATION PATTERN

Evaporator ice formation pattern analysis is helpful in ice machine diagnostics.

Analyzing the ice formation pattern alone cannot diagnose an ice machine malfunction.

However, it's important to keep in mind that any number of problems can cause improper ice formation.



All Undercounter Cubers

### Example of Evaporator Tubing Routing

#### Normal Ice Formation

Ice forms across the entire evaporator surface.

At the beginning of the Freeze cycle, it may appear that more ice is forming on the inlet of the evaporator than at the outlet. At the end of the Freeze cycle, ice formation at the outlet will be close to, or just a bit thinner than, ice formation at the inlet. The dimples in the cubes at the outlet of the evaporator may be more pronounced than those at the inlet. This is normal.

If ice forms uniformly across the evaporator surface, but does not do so in the proper amount of time, this is still considered a normal ice fill pattern.

### **Extremely Thin at Evaporator Outlet**

There is no ice, or a considerable lack of ice formation on the outlet of the evaporator.

Examples: No ice at all at the outlet of the evaporator, but ice forms at the inlet half of the evaporator. Or, the ice at the outlet of the evaporator reaches the correct thickness, but the outlet of the evaporator already has 1/2" to 1" of ice formation.

Possible cause: Water loss, low on refrigerant, starving TXV, hot water supply, faulty float valve, etc.

### **Extremely Thin at Evaporator Inlet**

There is no ice, or a considerable lack of ice formation at the inlet of the evaporator. Examples: The ice at the outlet of the evaporator reaches the correct thickness, but there is no ice formation at all at the inlet of the evaporator.

Possible cause: Insufficient water flow, flooding TXV, etc.

### **Spotty Ice Formation**

There are small sections on the evaporator where there is no ice formation. This could be a single corner, or a single spot in the middle of the evaporator. This is generally caused by loss of heat transfer from the tubing on the backside of the evaporator.

### **No Ice Formation**

The ice machine operates for an extended period, but there is no ice formation at all on the evaporator.

Possible cause: Water float valve, water pump, starving expansion valve, low refrigerant charge, compressor, etc.

## **ANALYZING DISCHARGE PRESSURE**

The discharge pressure is normal when the actual pressure falls within the published pressure range for the ice machine's operating conditions. It is normal for the discharge pressure to be higher at the beginning of the freeze cycle (when load is greatest), then drops throughout the freeze cycle.

## **Discharge Pressure High Checklist**

### ***Improper Installation***

- Refer to “Installation/Visual Inspection Checklist” on page 100

### ***Restricted Condenser Air Flow***

- High inlet air temperature
- Condenser discharge air re-circulation
- Dirty condenser fins
- Defective fan motor

### ***Improper Refrigerant Charge***

- Overcharged
- Non-condensable in system
- Wrong type of refrigerant

### ***Other***

- Non-Icetro components in system
- High side refrigerant lines/component restricted (before mid-condenser)

## **Freeze Cycle Discharge Pressure Low Checklist**

### ***Improper Installation***

- Refer to “Installation/Visual Inspection Checklist” on page 100

### ***Improper Refrigerant Charge***

- Undercharged
- Wrong type of refrigerant

### ***Other***

- Non-Icetro components in system
- High side refrigerant lines/component restricted (before mid-condenser)
- Defective fan cycle control

## **ANALYZING SUCTION PRESSURE**

The suction pressure gradually drops throughout the freeze cycle. The actual suction pressure (and drop rate) changes as the air and water temperature entering the ice machine changes. These variables also determine the freeze cycle times.

To analyze and identify the proper suction pressure drop throughout the freeze cycle, compare the published suction pressure to the published freeze cycle time.

**NOTE:** Analyze discharge pressure before analyzing suction pressure. High or low discharge pressure may be causing high or low suction pressure.

## **Suction Pressure High Checklist**

### ***Improper Installation***

- Refer to “Installation/Visual Inspection Checklist” on page 87.

### ***Discharge Pressure***

- Discharge pressure is too high, and is affecting suction pressure, refer to “Discharge Pressure High Checklist” on page 92.

### ***Improper Refrigerant Charge***

- Overcharged
- Wrong type of refrigerant
- Non-condensable in system

### ***Other***

- Non-icetro components in system
- Hot Gas valve leaking
- TXV flooding (check bulb mounting)
- Defective compressor

## Suction Pressure Low Checklist

### ***Improper Installation***

- Refer to “Installation/Visual Inspection Checklist” on page 87.

### ***Discharge Pressure***

- Discharge pressure is too low, and is affecting suction pressure, refer to “Freeze Cycle Discharge Pressure Low Checklist” on page 92.

### ***Improper Refrigerant Charge***

- Undercharged
- Wrong type of refrigerant

### ***Other***

- Non-Icetro components in system
- Improper water supply over evaporator refer to “Water System Checklist” on page 87.
- Loss of heat transfer from tubing on back side of evaporator
- Restricted/plugged liquid line drier
- Restricted/plugged tubing in suction side of refrigeration system
- TXV starving

NOTE: Do not limit your diagnosis to only the items listed in the checklists.

## **HOT GAS VALVE**

### **General**

The hot gas valve is an electrically operated valve that opens when energized, and closes when de-energized.

### **Normal Operation**

The valve is de-energized (closed) during the freeze cycle and energized (open) during the harvest cycle. The valve is positioned between the compressor and the evaporator and performs two functions:

1. Prevents refrigerant from entering the evaporator during the freeze cycle.

The hot gas valve is not used during the freeze cycle. The hot gas valve is de-energized (closed) preventing refrigerant flow from the compressor into the evaporator.

2. Allows refrigerant vapor to enter the evaporator in the harvest cycle.

During the harvest cycle, the hot gas valve is energized (open) allowing refrigerant gas from the discharge line of the compressor to flow into the evaporator. The heat is absorbed by the evaporator and allows the release of the ice slab.

Exact temperatures vary according to ambient temperature and ice machine model.

## **Hot Gas Valve Analysis**

The valve can fail in two positions:

- Valve will not open in the harvest cycle.
- Valve remains open during the freeze cycle.

### VALVE WILL NOT OPEN IN THE HARVEST CYCLE

Although the circuit board has initiated a harvest cycle, the evaporator temperature remains unchanged from the freeze cycle.

### VALVE REMAINS OPEN IN THE FREEZE CYCLE:

Symptoms of a hot gas valve remaining partially open during the freeze cycle can be similar to symptoms of an expansion valve, float valve or compressor problem. Symptoms are dependent on the amount of leakage in the freeze cycle.

A small amount of leakage will cause increased freeze times and an ice fill pattern that is “Thin at the Outlet”, but fills in at the end of the cycle.

As the amount of leakage increases the length of the freeze cycle increases and the amount of ice at the outlet of the evaporator decreases.

If replacement is necessary, use only “original” Ictro replacement parts.

Use the following procedure and table to help determine if a hot gas valve is remaining partially open during the freeze cycle.

1. Wait five minutes into the freeze cycle.
2. Feel the inlet of the harvest valve(s).

### **Important**

Feeling the harvest valve outlet or across the hot gas valve itself will not work for this comparison.

The hot gas valve outlet is on the suction side (cool refrigerant). It may be cool enough to touch even if the valve is leaking.

3. Feel the compressor discharge line.

### **⚠ Warning**

The inlet of the hot gas valve and the compressor discharge line could be hot enough to burn your hand. Just touch them momentarily.

4. Compare the temperature of the inlet of the hot gas valve to the temperature of the compressor discharge line.

<b>Findings</b>	<b>Comments</b>
<p>The inlet of the hot gas valve is cool enough to touch and the compressor discharge line is hot.</p> <p><b>Cool &amp; Hot</b></p>	<p>This is normal as the discharge line should always be too hot to touch and the hot gas valve inlet, although too hot to touch during harvest, should be cool enough to touch after 5 minutes into the freeze cycle.</p>
<p>The inlet of the hot gas valve is hot and approaches the temperature of a hot compressor discharge line.</p> <p><b>Hot &amp; Hot</b></p>	<p>This is an indication something is wrong, as the hot gas valve inlet did not cool down during the freeze cycle. If the compressor dome is also entirely hot, the problem is not a harvest valve leaking, but rather something causing the compressor (and the entire ice machine) to get hot.</p>
<p>Both the inlet of the hot gas valve and the compressor discharge line are cool enough to touch.</p> <p><b>Cool &amp; Cool</b></p>	<p>This is an indication something is wrong, causing the compressor discharge line to be cool to the touch. This is not caused by a hot gas valve leaking.</p>

## **DISCHARGE LINE TEMPERATURE ANALYSIS**

### **GENERAL**

Knowing if the discharge line temperature is increasing, decreasing or remaining constant can be an important diagnostic tool. Maximum compressor discharge line temperature on a normally operating ice machine steadily increases throughout the freeze cycle. Comparing the temperatures over several cycles will result in a consistent maximum discharge line temperature.

Ambient air temperatures affect the maximum discharge line temperature.

Higher ambient air temperatures at the condenser = higher discharge line temperatures at the compressor.

Lower ambient air temperatures at the condenser = lower discharge line temperatures at the compressor.

Regardless of ambient temperature, the freeze cycle discharge line temperature will be higher than 150°F (66°C) on a normally operating ice machine.

### **PROCEDURE**

Connect a temperature probe on the compressor discharge line within 6" (15.2 cm) of the compressor. Observe the discharge line temperature for the last three minutes of the freeze cycle and record the maximum discharge line temperature.

**Discharge Line Temperature Above 150°F (66°C) at End of Freeze Cycle:**

Ice machines that are operating normally will have consistent discharge line temperatures above 150°F (66°C).

Verify the expansion valve sensing bulb is positioned and secured correctly.

**Discharge Line Temperature Below 150°F (66°C) at End of Freeze Cycle**

Ice machines that have a flooding expansion valve will have a discharge line temperature that decreases each cycle.

Verify the expansion valve sensing bulb is 100% insulated and sealed airtight. Condenser air contacting an incorrectly insulated sensing bulb will cause overfeeding of the expansion valve.

## **Final Analysis**

### **Hot Gas Valve Leaking**

A leaking hot gas valve must be replaced.

### **Low Charge/TXV Starving**

Normally, a starving expansion valve only affects the freeze cycle pressures, not the harvest cycle pressures. A low refrigerant charge normally affects both pressures. Verify the ice machine is not low on charge before replacing an expansion valve.

Add refrigerant charge in 2 oz. increments as a diagnostic procedure to verify a low charge. (Do not add more than the total charge of refrigerant). If the problem is corrected, the ice machine is low on charge. Find the refrigerant leak.

The ice machine must operate with the nameplate charge. If the leak cannot be found, proper refrigerant procedures must still be followed. Change the liquid line drier, evacuate the system and weigh in the proper charge.

If the problem is not corrected by adding charge, the expansion valve is faulty.

### **TXV Flooding**

A loose or improperly mounted expansion valve bulb causes the expansion valve to flood. Check bulb mounting, insulation, etc., before changing the valve.

## Troubleshooting WU-0100

### DIAGNOSING AN ICE MACHINE THAT WILL NOT RUN

#### Warning

High (line) voltage is applied to the control board at all times. Removing control board fuse or moving the 'ICE/OFF/WASH' switch to 'OFF' will not remove the power supplied to the control board.

1. Verify primary voltage is supplied to ice machine and the fuse/circuit breaker is closed.
2. Verify control board fuse is okay.
3. If the power light functions on the front of the machine, the fuse is okay.
4. Verify the bin switch functions properly. A defective bin switch can falsely indicate a full bin of ice.
5. Verify 'ICE/OFF/WASH' switch functions properly. A defective switch may keep the ice machine in the 'OFF' mode.
6. Verify the water filter cartridge (supplied) has been installed. **The machine will not run with out it.**
7. Be sure Steps 1 – 6 were followed thoroughly. Intermittent problems are not usually related to the control board.
8. Replace the control board.

## **Error Codes**

In addition to the standard safety controls, your Icetro ice machine features built-in error code that will stop the ice machine if conditions arise which could cause a major component failure.

### **Error Code #1:**

If the freeze time exceeds 65 minutes, 3 consecutive times, the error LED (red) will blink.

### **Error Code #2:**

If the harvest time exceeds 5 minutes, 3 consecutive times, the error LED (red) will light solid.

## **Error Code Checklist**

The following checklists are designed to assist the service technician in analysis. However, because there are many possible external problems, do not limit your diagnosis to only the items listed.

### **Error Code #1**

**Freeze time exceeds 65 minutes for 3 consecutive freeze cycles.**

Possible Cause Checklist

#### ***Improper installation***

- Refer to “Installation/Visual Inspection Checklist” on page 165

#### ***Water System***

- Water Level too high or defective float (water escaping water trough)
- Low water pressure (20 psig min.)
- High water pressure (80 psig max.)
- High water temperature (90°F/32.2°C max.)
- Clogged water distribution tube
- Defective water pump

### ***Electrical System***

- Harvest cycle not initiated electrically
- Compressor electrically non-operational
- Restricted condenser air flow
- High inlet air temperature (110°F/43.3°C max.)
- Condenser discharge air re-circulation
- Dirty condenser fins
- Defective fan motor
- Dirty condenser

### ***Refrigeration System***

- Non-Icetro components
- Improper refrigerant charge
- Defective compressor
- Non-condensable in refrigeration system
- Plugged or restricted high side refrigerant lines or component
- Defective hot gas valve

## **Safety Limit #2**

**Harvest time exceeds 5 minutes for 3 Consecutive harvest cycles.**

Possible Cause Checklist

### ***Improper installation***

- Refer to “Installation/Visual Inspection Checklist” on page 165

### ***Water System***

- Water area (evaporator) dirty
- Dirty/defective water dump valve
- Water freezing behind evaporator
- Plastic extrusions and gaskets not securely mounted to the evaporator
- Low water pressure (20 psig min.)
- Loss of water from sump area
- Clogged water distribution tube
- Dirty/defective water inlet float
- Defective water pump

### ***Electrical system***

- Bin switch defective
- Premature harvest

### ***Refrigeration system***

- Non-Icetro components
- Improper refrigerant charge
- Defective hot gas valve

## DIAGNOSING ICE THICKNESS CONTROL CIRCUITRY

### Ice Machine Does Not Cycle Into Harvest when Water Contacts the Ice Thickness Control Probe

**Step 1** Move the 'ICE/OFF/WASH' switch to 'OFF' and back to 'ON' to start a new cycle. Wait until the water starts to flow over the evaporator.

**Step 2** Use a jumper wire between the (red) ice thickness probe connector on the outside of the control box and any cabinet ground.

Step 2 Jumper red control box terminal to ground	
Monitoring Harvest Light	Correction
The ice machine cycles from freeze to harvest.	The ice thickness probe is causing the malfunction.
The machine does not cycle into harvest.	The control board is causing the malfunction.

## Ice Machine Cycles Into Harvest Before Water Contact with the Ice Thickness Probe

**Step 1** Move the 'ICE/OFF/WASH' switch to 'OFF' and back to 'ON' to start a new cycle. Wait until the water starts to flow over the evaporator.

**Step 2** Disconnect the ice thickness probe from the control box terminal.

<b>Step 2 Disconnect probe from control board terminal.</b>	
<b>Monitoring Harvest Light</b>	<b>Correction</b>
The ice machine remains in the freeze sequence.	The ice thickness probe is causing the malfunction. Verify that the Ice Thickness probe is adjusted correctly.
The ice machine cycles from freeze to harvest.	The control board is causing the malfunction.

## ICE PRODUCTION CHECK

The amount of ice a machine produces directly relates to the operating water and air temperatures. This means an ice machine with a 70°F (21°C) ambient temperature and 50°F (10°C) water produces more ice than the same ice machine with 90°F (32°C) ambient and 70°F (21°C) water.

1. Determine the ice machine operating conditions:  
 Air temp entering condenser: \_\_\_\_\_°  
 Air temp around ice machine: \_\_\_\_\_°  
 Water temp entering sump trough: \_\_\_\_\_°
2. Refer to the appropriate "Cycle Times, 24 Hr. Ice Production and Refrigerant Pressure Charts" on page 219. Use the operating conditions determined in Step 1 to find published 24-Hour Ice Production: \_\_\_\_\_
  - Times are in minutes.  
 Example: 1 min. 15 sec. converts to 1.25 min.  
 (15 seconds ÷ 60 seconds = .25 minutes)
  - Weights are in pounds.  
 Example: 2 lb. 6 oz. converts to 2.375 lb.  
 (6 oz. ÷ 16 oz. = .375 lb.)
3. Perform an ice production check using the formula below.

1.	$\frac{\text{Freeze Time}}{\quad}$	+	$\frac{\text{Harvest Time}}{\quad}$	=	$\frac{\text{Total Cycle Time}}{\quad}$
2.	$\frac{1440}{\text{Minutes in 24 Hrs.}}$	÷	$\frac{\text{Total Cycle Time}}{\quad}$	=	$\frac{\text{Cycles per Day}}{\quad}$
3.	$\frac{\text{Weight of One Harvest}}{\quad}$	x	$\frac{\text{Cycles per Day}}{\quad}$	=	$\frac{\text{Actual 24-Hour Production}}{\quad}$

4. Compare the results of step 3 with step 2. Ice production is normal when these numbers match closely. If they match closely, determine if:
  - Another larger ice machine is required.
  - Relocating the existing equipment to lower the load conditions is required.

Contact the local Icetro distributor for information on available options and accessories.

## INSTALLATION/VISUAL INSPECTION CHECKLIST

### ***Ice machine is not level***

- Level the ice machine

### ***Condenser is dirty***

- Clean the condenser

### ***Water filtration is not installed or plugged***

- Install a new water filter

### ***Water drains are not run separately and/or are not vented***

- Run and vent drains according to the Installation Manual

## **WATER SYSTEM CHECKLIST**

A water-related problem often causes the same symptoms as a refrigeration system component malfunction.

Water system problems must be identified and eliminated prior to replacing refrigeration components.

### ***Water area (evaporator) is dirty***

- Descale as needed

### ***Water inlet pressure not between 20 and 80 psig (1–5 bar, 138–552 kPa)***

- Install a water regulator valve or increase the water pressure

### ***Incoming water temperature is not between 50°F (10°C) and 90°F (32°C)***

- If too hot, check the hot water line check valves in other store equipment

### ***Water filtration is not installed or plugged***

- Install a new water filter

***Hoses, fittings, etc., are leaking water***

- Repair/replace as needed

***Water valve is stuck open, closed or is leaking***

- Descale/replace as needed

***Water is spraying out of the sump trough area***

- Stop the water spray

***Water is leaking through the sump trough overflow***

- Set the water level 1/4"-3/8" below standpipe

***Uneven water flow across the evaporator***

- Descale the ice machine

***Water is freezing behind the evaporator***

- Correct the water flow

## **WU-0100 Refrigeration Diagnostics**

This machine uses a capillary tube metering device system. An irregular ice fill pattern could indicate an improper refrigerant charge.

If this is determined to be the case, recover any refrigerant left in the system, evacuate the system and weigh in a new charge according to the machine's data plate.

**NOTE:** If the machine is low on charge, find the source of the leak before charging the system.

## **Analyzing Discharge Line Temperature**

### **Discharge Pressure High Checklist *Improper***

#### ***Installation***

- Refer to “Installation/Visual Inspection Checklist” on page 112

#### ***Restricted Condenser Air Flow***

- High inlet air temperature
- Condenser discharge air re-circulation
- Dirty condenser fins
- Defective fan motor

#### ***Improper Refrigerant Charge***

- Overcharged
- Non-condensable in system
- Wrong type of refrigerant

#### ***Other***

- Non-Icetro components in system
- High side refrigerant lines/component restricted (before mid-condenser)

### **Freeze Cycle Discharge Pressure Low Checklist**

#### ***Improper Installation***

- Refer to “Installation/Visual Inspection Checklist” on page 112

#### ***Improper Refrigerant Charge***

- Undercharged
- Wrong type of refrigerant

#### ***Other***

- Non-Icetro components in system
- High side refrigerant lines/component restricted (before mid-condenser)
- Defective fan cycle control

## **Analyzing Suction Line Temperature**

### **Suction Temperature High Checklist**

#### ***Improper Installation***

- Refer to “Installation/Visual Inspection Checklist” on page 112

#### ***Discharge Pressure***

- Discharge temperature is too high, and is affecting suction temperature, refer to “Discharge Line Temperature High Checklist” on page 116.

#### ***Improper Refrigerant Charge***

- Overcharged
- Wrong type of refrigerant
- Non-condensable in system

#### ***Other***

- Non-Icetro components in system
- Hot gas valve leaking
- Defective compressor

## **Suction Temperature Low Checklist**

### ***Improper Installation***

- Refer to “Installation/Visual Inspection Checklist” on page 112

### ***Discharge Pressure***

- Discharge temperature is too low, and is affecting suction temperature, refer to “Freeze Cycle Discharge Temperature Low Checklist” on page 116.

### ***Improper Refrigerant Charge***

- Undercharged
- Wrong type of refrigerant

### ***Other***

- Non-Icetro components in system
- Improper water supply over evaporator refer to “Water System Checklist” on page 113.
- Loss of heat transfer from tubing on back side of evaporator
- Restricted/plugged liquid line drier
- Restricted/plugged tubing in suction side of refrigeration system

NOTE: Do not limit your diagnosis to only the items listed in the checklists.

## **HOT GAS VALVE**

### **General**

The hot gas valve is an electrically operated valve that opens when energized, and closes when de-energized.

### **Normal Operation**

The valve is de-energized (closed) during the freeze cycle and energized (open) during the harvest cycle. The valve is positioned between the condenser and the evaporator and performs two functions:

1. Prevents refrigerant from entering the evaporator during the freeze cycle.

The hot gas valve is not used during the freeze cycle.

The hot gas valve is de-energized (closed) preventing refrigerant flow from the receiver into the evaporator.

2. Allows refrigerant vapor to enter the evaporator in the harvest cycle.

During the harvest cycle, the hot gas valve is energized (open) allowing refrigerant gas from the discharge line of the compressor to flow into the evaporator. The heat is absorbed by the evaporator and allows release of the ice slab.

Exact temperatures vary according to ambient temperature and ice machine model.

## Hot Gas Valve Analysis

The valve can fail in two positions:

- Valve will not open in the harvest cycle.
- Valve remains open during the freeze cycle.

### VALVE WILL NOT OPEN IN THE HARVEST CYCLE

Although the circuit board has initiated a harvest cycle, the evaporator temperature remains unchanged from the freeze cycle.

### VALVE REMAINS OPEN IN THE FREEZE CYCLE:

Symptoms of a hot gas valve remaining partially open during the freeze cycle can be similar to symptoms of an expansion valve, float valve or compressor problem. Symptoms are dependent on the amount of leakage in the freeze cycle.

A small amount of leakage will cause increased freeze times and an ice fill pattern that is “Thin at the Outlet”, but fills in at the end of the cycle.

As the amount of leakage increases the length of the freeze cycle increases and the amount of ice at the outlet of the evaporator decreases.

If replacement is necessary, use only “original” Icetro replacement parts.

Use the following procedure and table to help determine if a hot gas valve is remaining partially open during the freeze cycle.

1. Wait five minutes into the freeze cycle.
2. Feel the inlet of the harvest valve(s).

### **Important**

Feeling the hot gas valve outlet or across the hot gas valve itself will not work for this comparison.

The hot gas valve outlet is on the suction side (cool refrigerant). It may be cool enough to touch even if the valve is leaking.

3. Feel the compressor discharge line.

### **Warning**

The inlet of the hot gas valve and the compressor discharge line could be hot enough to burn your hand. Just touch them momentarily.

4. Compare the temperature of the inlet of the hot gas valve to the temperature of the compressor discharge line.

<b>Findings</b>	<b>Comments</b>
<p>The inlet of the hot gas valve is cool enough to touch and the compressor discharge line is hot.</p> <p style="text-align: center;"><b>Cool &amp; Hot</b></p>	<p>This is normal as the discharge line should always be too hot to touch and the hot gas valve inlet, although too hot to touch during harvest, should be cool enough to touch after 5 minutes into the freeze cycle.</p>
<p>The inlet of the hot gas valve is hot and approaches the temperature of a hot compressor discharge line.</p> <p style="text-align: center;"><b>Hot &amp; Hot</b></p>	<p>This is an indication something is wrong, as the hot gas valve inlet did not cool down during the freeze cycle. If the compressor dome is also entirely hot, the problem is not a harvest valve leaking, but rather something causing the compressor (and the entire ice machine) to get hot.</p>
<p>Both the inlet of the hot gas valve and the compressor discharge line are cool enough to touch.</p> <p style="text-align: center;"><b>Cool &amp; Cool</b></p>	<p>This is an indication something is wrong, causing the compressor discharge line to be cool to the touch. This is not caused by a hot gas valve leaking.</p>

# Component Check Procedures

## MAIN FUSE

### Function

The control board fuse stops ice machine operation if electrical components fail causing high amp draw.

### Specifications

- IC-0170/IU-0170/IC-0220/IU-0220 - 250 Volt, 5 amp
- WU-0100 - 250 Volt 1 amp

### Warning

High (line) voltage is applied to the control board at all times. Removing the control board fuse or pressing the power button will not remove the power supplied to the control board.

### Check Procedure

1. If the power light is lit on the front of the machine, the fuse is good.

### Warning

Disconnect electrical power to the entire ice machine before proceeding.

2. Remove the fuse. Check for continuity across the fuse with an ohmmeter.

Reading	Result
Open (OL)	Replace fuse
Closed (0)	Fuse is good

## **BIN SWITCH**

### **All Models**

#### **Function**

Bin switch operation is controlled by the movement of the ice damper. The bin switch has two main functions:

1. Terminating the harvest cycle and returning the ice machine to the freeze cycle.  
This occurs when the bin switch is opened and closed again within 7 seconds of opening during the harvest cycle.
2. Automatic ice machine shut-off.  
If the storage bin is full at the end of a harvest cycle, the sheet of cubes fails to clear the ice damper and holds it down. After the ice damper is held down for 7 seconds, the ice machine shuts off.  
The ice machine remains off until enough ice is removed from the storage bin to allow the sheet of cubes to drop clear of the ice damper. As the ice damper swings back to the operating position, the bin switch closes and the ice machine restarts.

### **Important**

The ice damper must be up (bin switch closed) to start ice making.

### **Check Procedure**

1. Toggle the 'ICE/OFF/WASH' switch to 'OFF'.
2. Watch the 'FULL' light on the front of the machine.
3. Move the ice damper upward, toward the evaporator. The bin switch must close. The 'FULL' light off indicates the bin switch has closed properly.
4. Move the ice damper away from the evaporator. The bin switch must open. The 'FULL' light on indicates the bin switch has opened properly.

### **Testing The Bin Switch**

1. Disconnect the bin switch from the control board.
2. Jumper control board bin switch wire to ground and observe the 'FULL' light on the front of the machine.
3. If the 'FULL' turns off, replace the bin switch.
4. If the 'FULL' light stays on, replace the board.

## FLOAT SWITCH

IC-0170/IU-0170/IC-0220/IU-0220

### Function

The ice machine uses two float switches, which open and close to indicate to the control board the level of water in the water trough.

Low-Level/Harvest Float -Indicates the water level has reached it's minimum point and verifies when the water level is low enough to initiate a harvest sequence.

High-Level/Ice Thickness Float -Indicates the water level has been reached for the appropriate ice thickness setting.

### Specifications

Normally closed, float operated magnetic reed switch.

The float switch contacts are closed in the down position. When water raises the float to the up position the magnet in the float opens the contacts.

### **Caution**

Do not disassemble float for Descaling - Incorrect reassembly of the float will result in an ice machine that will not harvest.

## Testing The Float Switch:

A simple continuity test can be used to test both of the float switches.

1. Disconnect power to the ice machine and disconnect the wire connector for the float switch on the backside of the bulkhead.
2. Attach an ohm meter lead to each float switch wires.
3. Place the float in the down position - The float switch should read closed.
4. Place the float in the up position - The float switch should read open.

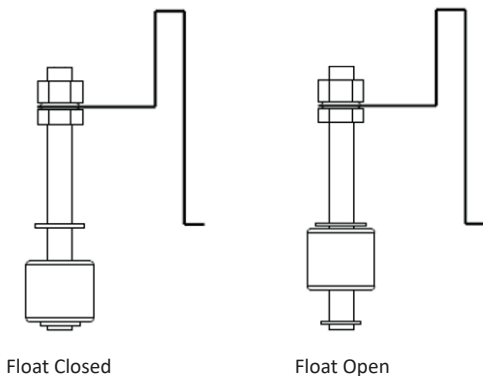

NOTE: Make adjustments with the float while testing it by moving the float in a circular motion while moving it up and down to ensure there are no "dead spots" causing inaccurate readings.

Replace float if at any time it reads open in the down position or closed in the up position.

Float	Float Up	Float Down
High-Level Ice Thickness Float	OL	< 1 Ohm
Low-Level Float	OL	< 1 Ohm

## **WATER TROUGH THERMISTOR IC-0170/IU-0170/IU-0220/IU-01220**

### **Function**

Thermistor resistance values change with temperature. The value supplied to the control board is used to identify temperature at the thermistor location.

### **Check procedure**

If the thermistor is open or shorted, replace it.

## **ICE/OFF/WASH TOGGLE SWITCH**

### **All Models**

#### **FUNCTION**

The switch is used to place the ice machine in ICE, OFF or WASH mode of operation.

#### **SPECIFICATIONS**

Single-pole, double-throw switch.

#### **CHECK PROCEDURE**

1. Inspect the toggle switch for correct wiring.
2. Isolate the toggle switch by disconnecting all wires from the switch.
3. Check for continuity across the toggle switch terminals using a calibrated ohmmeter.

## **COMPRESSOR ELECTRICAL DIAGNOSTICS**

The compressor does not start or will trip repeatedly on overload.

### **Check Resistance (Ohm) Values**

NOTE: Compressor windings can have very low ohm values. Use a properly calibrated meter.

Perform the resistance test after the compressor cools. The compressor dome should be cool enough to touch (below 120°F/49°C) to ensure that the overload is closed and the resistance readings will be accurate.

### **Single Phase Compressors**

1. Disconnect power from the machine and remove the wires from the compressor terminals.
2. The resistance values between C and S and between C and R, when added together should equal the resistance value between S and R.
3. If the overload is open, there will be a resistance reading between S and R, and open readings between C and S and between C and R. Allow the compressor to cool, then check the readings again.

### **Check Motor Windings to Ground**

Check continuity between all three terminals and the compressor shell or copper refrigeration line. Scrape metal surface to get good contact. If continuity is present, the compressor windings are grounded and the compressor should be replaced.

To determine if the compressor is seized check the amp draw while the compressor is trying to start.

## **Compressor Drawing Locked Rotor**

The two likely causes of this are:

- Defective starting component
- Mechanically seized compressor

To determine which you have:

1. Install high and low side gauge.
2. Try to start the compressor.
3. Watch the pressures closely.
  - If the pressures do not move, the compressor is seized. Replace the compressor.
  - If the pressures move, the compressor is turning slowly and is not seized. Check the capacitors and relay.

## **Compressor Drawing High Amps**

The continuous amperage draw on start-up should not be near the maximum fuse size indicated on the serial tag.

The wiring must be correctly sized to minimize voltage drop at compressor start-up. The voltage when the compressor is trying to start must be within  $\pm 10\%$  of the nameplate voltage.

## HIGH PRESSURE CUTOUT (HPCO) CONTROL IC-0170/IU-0170/IU-0220/IU-0220

### Function

Stops the ice machine if subjected to excessive high-side pressure.

The HPCO control is normally closed, and opens on a rise in discharge pressure.

### Specifications

Cut-out: 426 psig  $\pm$ 10

Cut-in: Automatic reset

(Must be below 355 psig to reset)

### Check Procedure

1. Set the 'ICE/OFF/WASH' switch to 'OFF'.
2. Connect manifold gauge.
3. Hook voltmeter in parallel across the HPCO, leaving wires attached.
4. Set the 'ICE/OFF/WASH' switch to 'ON' - No air flowing through the condenser will cause the HPCO control to open because of excessive pressure. Watch the pressure gauge and record the cut-out pressure.

### Warning

If discharge pressure exceeds 426 psig and the HPCO control does not open, disconnect the power to stop ice machine operation.

Replace the HPCO control if it:

- Will not reset (below 355 psig)
- Does not open at the specified cut-out point

## Filter-Driers

### Liquid Line Filter Drier

The filter-drier used on Icetro ice machines are manufactured to Icetro specifications. Always make sure to use an (O.E.M.) filter-drier when opening the refrigeration system.

#### **Important**

The liquid line drier is covered as a warranty part. The liquid line drier must be replaced any time the system is opened for repair.

# Refrigerant Recovery/Evacuation

## DEFINITIONS

### Recover

To remove refrigerant, in any condition, from a system and store it in an external container, without necessarily testing or processing it in any way.

### Recycle

To clean refrigerant for re-use by oil separation and single or multiple passes through devices, such as replaceable core filter-driers, which reduce moisture, acidity and particulate matter. This term usually applies to procedures implemented at the field job site or at a local service shop.

### Reclaim

To reprocess refrigerant to new product specifications (see below) by means which may include distillation. A chemical analysis of the refrigerant is required after processing to be sure that product specifications are met. This term usually implies the use of processes and procedures available only at a reprocessing or manufacturing facility.

Chemical analysis is the key requirement in this definition. Regardless of the purity levels reached by a reprocessing method, refrigerant is not considered “reclaimed” unless it has been chemically analyzed and meets ARI Standard 700 (latest edition).

### New Product Specifications

This means ARI Standard 700 (latest edition). Chemical analysis is required to assure that this standard is met.

## REFRIGERANT RE-USE POLICY

Icetro recognizes and supports the need for proper handling, re-use, and disposal of refrigerants. Icetro service procedures require recapturing refrigerants, not venting them to the atmosphere.

It is not necessary, in or out of warranty, to reduce or compromise the quality and reliability of your customers' products to achieve this.

### **Important**

Icetro America assumes no responsibility for use of contaminated refrigerant. Damage resulting from the use of contaminated, recovered, or recycled refrigerant is the sole responsibility of the servicing company.

Icetro approves the use of:

1. New Refrigerant
  - Must be of original nameplate type.
2. Reclaimed Refrigerant
  - Must be of original nameplate type.
  - Must meet ARI Standard 700 (latest edition) specifications.
3. Recovered or Recycled Refrigerant
  - Must be recovered or recycled in accordance with current local, state and federal laws.
  - Must be recovered from and re-used in the same Icetero product. Re-use of recovered or recycled refrigerant from other products is not approved.

4. Recovered refrigerant must come from a “contaminant-free” system. To decide whether the system is contaminant free, consider:
  - Type(s) of previous failure(s)
  - Whether the system was cleaned, evacuated and recharged properly following failure(s)
  - Whether the system has been contaminated by this failure
  - Compressor motor burnouts and improper past service prevent refrigerant re-use.
  - Refer to page 145 to test for contamination.
5. “Substitute” or “Alternative” Refrigerant
  - No substitute or alternative refrigerants are allowed without expressed, written approval from Icetrol America.

## RECOVERY AND RECHARGING PROCEDURES IC-0170/IU-0170/IC-0220/IU-0220

Do not purge refrigerant to the atmosphere. Capture refrigerant using recovery equipment. Follow the manufacturer's recommendations.

### **Important**

Icetro America assumes no responsibility for the use of contaminated refrigerant. Damage resulting from the use of contaminated refrigerant is the sole responsibility of the servicing company.

### **Important**

Replace the liquid line drier before evacuating and recharging. Use only a Icetro (O.E.M.) liquid line filter drier to prevent voiding the warranty.

## CONNECTIONS

1. Suction side of the compressor through the suction service valve.
2. Discharge side of the compressor through the discharge service valve.

## SELF-CONTAINED RECOVERY/EVACUATION

1. Place the 'ICE/OFF/WASH' switch in the 'OFF' position.
2. Install manifold gauge set, charging cylinder/scale, and recovery unit or two-stage vacuum pump.
3. Open high and low side on manifold gauge set.
4. Perform recovery or evacuation:
  - A. Recovery: Operate the recovery unit as directed by the manufacturer's instructions.
  - B. Evacuation prior to recharging: Pull the system down to 500 microns. Then, allow the pump to run for an additional half hour. Turn off the pump and perform a standing vacuum leak check.

NOTE: Check for leaks using an electronic leak detector after charging the ice machine.

Follow the Charging Procedures below.

## CHARGING PROCEDURES

### **Important**

The charge is critical on all Icetrol ice machines. Use a scale or a charging cylinder to ensure the proper charge is installed.

1. Be sure the 'ICE/OFF/WASH' switch is in the 'OFF' position.
2. Close the vacuum pump valve and the low side manifold gauge valve.
3. Open the high side manifold gauge valve.
4. Open the charging cylinder and add the proper refrigerant charge (shown on nameplate) through the discharge service valve.
5. Let the system "settle" for 2 to 3 minutes.
6. Set the 'ICE/OFF/WASH' switch to the 'ON' position.

7. Close the high side on the manifold gauge set.

NOTE: Manifold gauge set must be removed properly to ensure that no refrigerant contamination or loss occurs.

8. Make sure that all of the vapor in the charging hoses is drawn into the ice machine before disconnecting the charging hoses.
  - A. Run the ice machine in freeze cycle.
  - B. Disconnect the low loss fitting from the high side access valve at the ice machine.
  - C. Remain connected to the low side access valve at the ice machine.
  - D. Open the high and low side valves on the manifold gauge set. Any refrigerant in the lines will be pulled into the low side of the system.
  - E. Allow the pressures to equalize while the ice machine is in the freeze cycle.
9. Remove the hoses from the ice machine and install the caps.

## RECOVERY AND RECHARGING PROCEDURES WU-0100

Do not purge refrigerant to the atmosphere. Capture refrigerant using recovery equipment. Follow the manufacturer's recommendations.

### **Important**

Icetro America assumes no responsibility for the use of contaminated refrigerant. Damage resulting from the use of contaminated refrigerant is the sole responsibility of the servicing company.

### **Important**

Replace the liquid line drier before evacuating and recharging. Use only a Icetro (O.E.M.) liquid line filter drier to prevent voiding the warranty.

## CONNECTIONS

These ice machines are critically charged. Use the low side access port to add and/or remove refrigerant.

1. Locate the low side process tube.

### **Important**

- Unit is critically charged. Nitrogen must be purged through the system while brazing to prevent build up of copper oxide in the refrigeration system.
- Manifold gauge set must be removed properly to ensure that no refrigerant contamination or loss occurs. Low loss fittings are recommended for the low side connection.

## RECOVERY/EVACUATION

1. Set the 'ICE/OFF/WASH' switch in the 'OFF' position.
2. Install manifold gauge set, charging scale, and recovery unit or two-stage vacuum pump.
3. Open low side valve on manifold gauge set.
4. Perform recovery or evacuation:
  - A. Recovery: Operate the recovery unit as directed by the manufacturer's instructions.
  - B. Evacuation prior to recharging: Pull the system down to 500 microns. Then, allow the pump to run for an additional half hour. Turn off the pump and perform a standing vacuum leak check.

NOTE: Check for leaks using a halide or electronic leak detector after charging the ice machine.

## CHARGING PROCEDURES

### **Important**

The charge is critical on all Icetro ice machines. Use a scale to ensure the proper charge is installed.

1. Verify the 'ICE/OFF/WASH' switch is in the 'OFF' position.
2. Close the vacuum pump valve.
3. Open the refrigerant cylinder and break the vacuum with 1-2 oz. of refrigerant through the suction access valve.
4. Place the toggle switch in the 'ICE' position.
5. Weigh in the remainder of the refrigerant charge, per the data plate specifications.

NOTE: Manifold gauge set must be removed properly to ensure that no refrigerant contamination or loss occurs.

## System Contamination Cleanup

This section describes the basic requirements for restoring contaminated systems to reliable service.

### **Important**

Icetro America assumes no responsibility for the use of contaminated refrigerant. Damage resulting from the use of contaminated refrigerant is the sole responsibility of the servicing company.

### **DETERMINING SEVERITY OF CONTAMINATION**

System contamination is generally caused by either moisture or residue from compressor burnout entering the refrigeration system.

Inspection of the refrigerant usually provides the first indication of system contamination. Obvious moisture or an acrid odor in the refrigerant indicates contamination.

If either condition is found, or if contamination is suspected use a test kit.

If a refrigerant test kit indicates harmful levels of contamination, or if a test kit is not available, inspect the compressor oil.

1. Remove the refrigerant charge from the ice machine.
2. Remove the compressor from the system.
3. Check the odor and appearance of the oil.
4. Inspect open suction and discharge lines at the compressor for burnout deposits.
5. If no signs of contamination are present, perform an acid oil test to determine the type of cleanup required.

<b>Contamination/Cleanup Chart</b>	
<b>Symptoms/Findings</b>	<b>Required Cleanup Procedure</b>
No symptoms or suspicion of contamination	Normal evacuation/recharging procedure
Moisture/Air Contamination symptoms Refrigeration system open to atmosphere for longer than 15 minutes Refrigeration test kit and/or acid oil test shows contamination No burnout deposits in open compressor lines	Mild contamination cleanup procedure
Mild Compressor Burnout symptoms Oil appears clean but smells acrid Refrigeration test kit or acid oil test shows harmful acid content No burnout deposits in open compressor lines	Mild contamination cleanup procedure
Severe Compressor Burnout symptoms Oil is discolored, acidic, and smells acrid Burnout deposits found in the compressor, lines, and other components	Severe contamination cleanup procedure

## **MILD SYSTEM CONTAMINATION CLEANUP PROCEDURE**

1. Replace any failed components.
2. If the compressor is good, change the oil.
3. Replace the liquid line drier.

NOTE: If the contamination is from moisture, use heat lamps during evacuation. Position them at the compressor, condenser and evaporator prior to evacuation. Do not position heat lamps too close to plastic components, or they may melt or warp.

4. Follow the normal evacuation procedure, except replace the evacuation step with the following:
  - A. Pull vacuum to 1000 microns. Break the vacuum with dry nitrogen and sweep the system. Pressurize to a minimum of 5 psig.
  - B. Pull vacuum to 500 microns. Break the vacuum with dry nitrogen and sweep the system. Pressurize to a minimum of 5 psig.
  - C. Change the vacuum pump oil.
  - D. Pull vacuum to 500 microns. Run the vacuum pump for 1/2 hour on self-contained models, 1 hour on remotes.

NOTE: You may perform a pressure test as a preliminary leak check. You should use an electronic leak detector after system charging to be sure there are no leaks.

5. Charge the system with the proper refrigerant to the nameplate charge.
6. Operate the ice machine.

## **SEVERE SYSTEM CONTAMINATION CLEANUP PROCEDURE**

1. Remove the refrigerant charge.
2. Remove the compressor.
3. If burnout deposits are found, replace the TXV.
4. Wipe away any burnout deposits from suction and discharge lines at compressor.
5. Sweep through the open system with dry nitrogen.
6. Install a new compressor and new start components.
7. Install suction line filter-drier in front of compressor.
8. Install a new liquid line drier.
9. Follow the normal evacuation procedure, except replace the evacuation step with the following:
  - A. Pull vacuum to 1000 microns. Break the vacuum with dry nitrogen and sweep the system. Pressurize to a minimum of 5 psig.
  - B. Change the vacuum pump oil.
  - C. Pull vacuum to 500 microns. Break the vacuum with dry nitrogen and sweep the system. Pressurize to a minimum of 5 psig.
  - D. Change the vacuum pump oil.
  - E. Pull vacuum to 500 microns. Run the vacuum pump for 1 additional hour.

10. Charge the system with the proper refrigerant to the nameplate charge.
11. Operate the ice machine for one hour. Then, check the pressure drop across the suction line filter-drier.
  - A. If the pressure drop is less than 2 psig, the filter-drier should be adequate for complete cleanup.
  - B. If the pressure drop exceeds 2 psig, change the suction line filter-drier and the liquid line drier. Repeat until the pressure drop is acceptable.
12. Operate the ice machine for 48 – 72 hours. Replace the suction line and liquid line drier if necessary.
13. Follow normal evacuation procedures.

## REPLACING PRESSURE CONTROLS WITHOUT REMOVING REFRIGERANT CHARGE

This procedure reduces repair time and cost. Use it when any of the following components require replacement, and the refrigeration system is operational and leak-free.

- High pressure cut-out control
  - High side access valve
  - Low side access valve
1. Disconnect power to the ice machine.
  2. Follow all manufacturers' instructions supplied with the pinch-off tool. Position the pinch-off tool around the tubing as far from the pressure control as feasible. Clamp down on the tubing until the pinch-off is complete

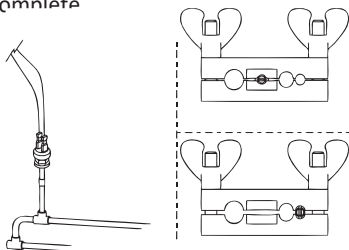

### **⚠ Warning**

Do not unsolder a defective component. Cut it out of the system. Do not remove the pinch-off tool until the new component is securely in place.

3. Cut the tubing of the defective component with a small tubing cutter.
4. Solder the replacement component in place. Allow the solder joint to cool.
5. Remove the pinch-off tool.
6. Re-round the tubing.

NOTE: The pressure controls will operate normally once the tubing is re-rounded. Tubing may not re-round 100%.

## Total System Refrigerant Charge

### Important

This information is for reference only. Refer to the ice machine serial number tag to verify the system charge. Serial plate information overrides information listed on this page.

Model	Air-Cooled	Water-Cooled	Refrigerant Type
WU-0100	6.7 oz	NA	R134A
IC-0170	14.11 oz	NA	R404A
IU-0170	14.11 oz	NA	R404A
IC-0220	14.11 oz	NA	R404A
IU-0220	14.11 oz	NA	R404A

## Charts

### **Cycle Times, 24 Hr. Ice Production and Refrigerant Pressure Charts**

These charts are used as guidelines to verify correct ice machine operation.

Accurate collection of data is essential to obtain the correct diagnosis.

- Production and cycle times are for dice cube - Half dice cube cycle times can be 1-2 minutes faster depending on model and ambient temperature.
- Ice production checks that are within 10% of the chart are considered normal. This is due to variances in water and air temperature. Actual temperatures will seldom match the chart exactly.
- Zero out manifold gauge set before obtaining pressure readings to avoid mis-diagnosis.
- Discharge and suction pressure are highest at the beginning of the cycle. Suction pressure will drop throughout the cycle. Verify the pressures are within the range indicated.
- Record beginning of freeze cycle suction pressure one minute after the water pump energizes.

## WU-0100

### SELF-CONTAINED AIR-COOLED

NOTE: These characteristics will vary depending on operating conditions.

#### Cycle Times

Freeze Time + Harvest Time = Total Cycle Time

Model	Ambient Temp.(C/F)	10/50	21/70	32/90	38/100
WU-0100-AC	Water Temp.(C/F)	10/50	10/50	21/70	32/90
	Ice Production(lb/d)	113	105	74	56
	Freeze Cycle Time(min)	12.8	14.6	21.4	28.9
	Defrost Cycle Time(min)	2.5	1.7	1.1	0.9
	1 Cycle Time(min)	15.4	16.3	22.6	29.8
	Electric Consumption(W)	220	220	250	280
	Head Pressure[Peak] (psig)	81	105	146	166
	Suction Pressure Peak (psig)	4.6	5	6.3	8
	Evaporator Inlet Temp. (F)	-4	-3	0	2.5

**IC-0170/IU-0170/IC-0220/IU-0220****SELF-CONTAINED AIR-COOLED**

NOTE: These characteristics may vary depending on operating conditions.

**Cycle Times**

Freeze Time + Harvest Time = Total Cycle Time

Model	Ambient Temp.(C/F)	10/50	21/70	32/90	38/100
IU-0170/0220-AC/AH	Water Temp.(C/F)	10/50	10/50	21/70	32/90
	Ice Production(lb/d)	198	191	150	105
	Freeze Cycle Time(min)	18.4	18.5	24.1	32.1
	Defrost Cycle Time(min)	2.1	2	1.2	1
	1 Cycle Time(min)	20.5	20.5	25.3	33.1
	Electric Consumption(W)	400	400	450	520
	Head Pressure[Peak] (psig)	232	232	278	322
	Suction Pressure Peak (psig)	28	29	35	38
	Evaporator Inlet Temp.(F)	0	1	6.4	8.4

# Diagrams

## Wiring Diagrams

The following pages contain electrical wiring diagrams. Be sure you are referring to the correct diagram for the ice machine you are servicing.

 **Warning**

Always disconnect power before working on electrical circuitry.

# WU-0100 WIRING DIAGRAM

## Self Contained Air-cooled

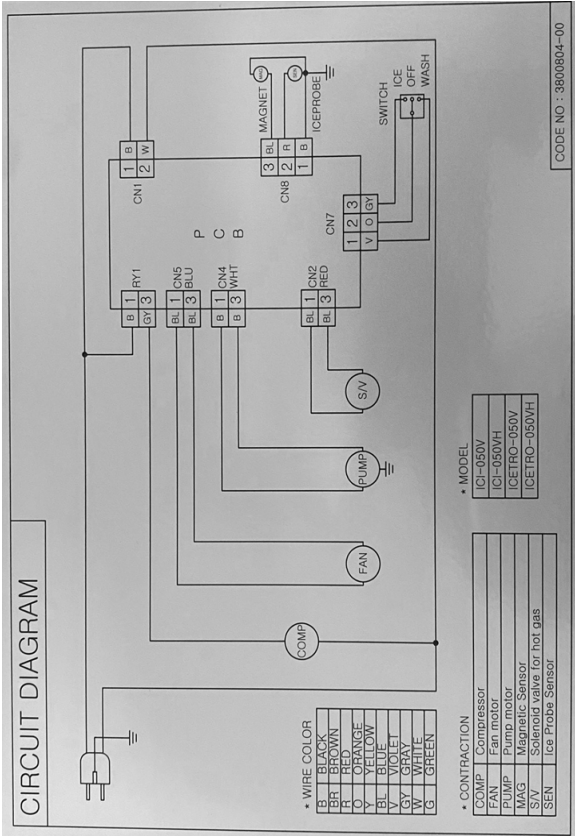

# IC-0170/IU-0170/IC-0220/IU-0220 WIRING DIAGRAM

Self Contained Air-cooled

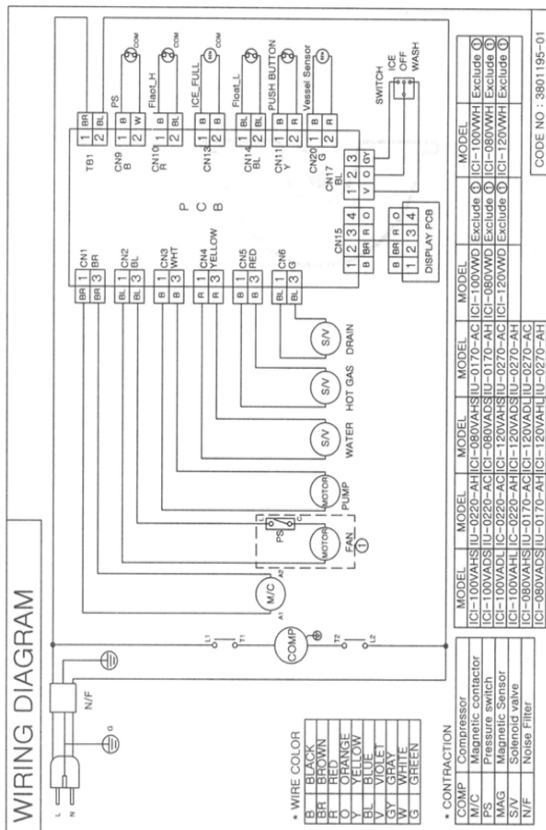

# Printed Circuit Bards (PCB)

## WU-0100 PCB

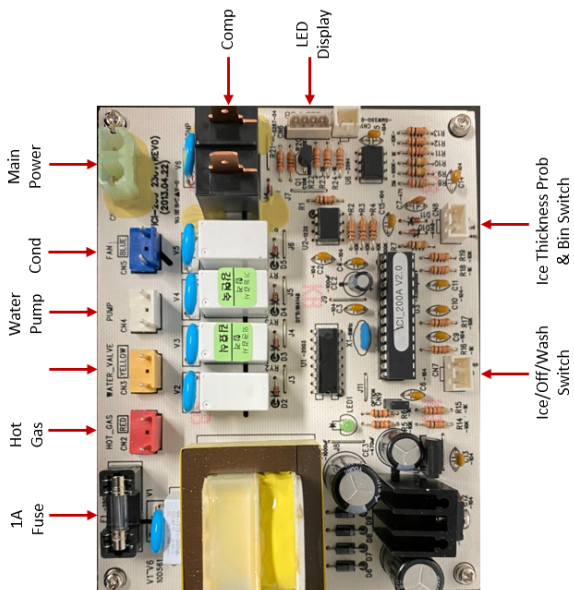

# IC-0170/IU-0170/IC-0220/IU-0220 PCB

Part # 415010200 - V1 PCB Using High/Low Floats

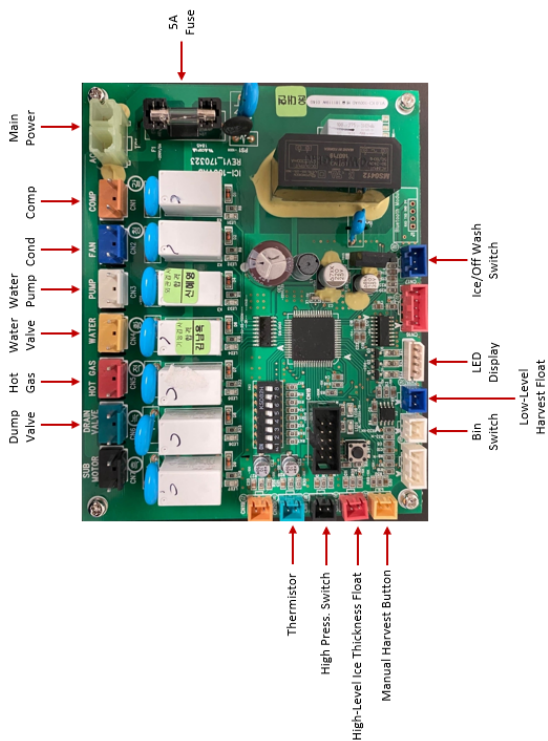

NOTE: PCB is backwards compatible with the original part # 415009100

# IC-0170/IU-0170/IC-0220/IU-0220 PCB

## Part # 415010201 - V2 PCB Using Ice Thickness Probe

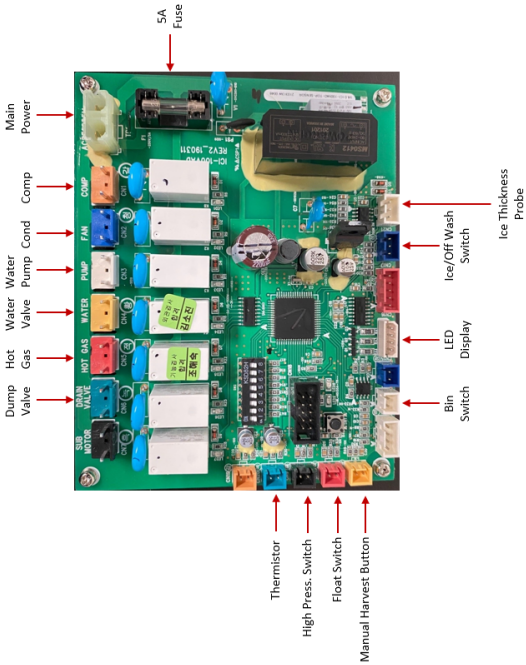

NOTE: PCB is not backwards compatible with part # 415009100 or part # 415010200

# Tubing Schematics

## TUBING SCHEMATIC - WU-0100

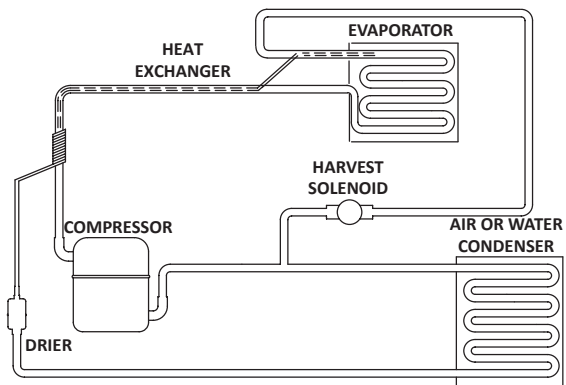

## TUBING SCHEMATIC - IU0170 & IU0220

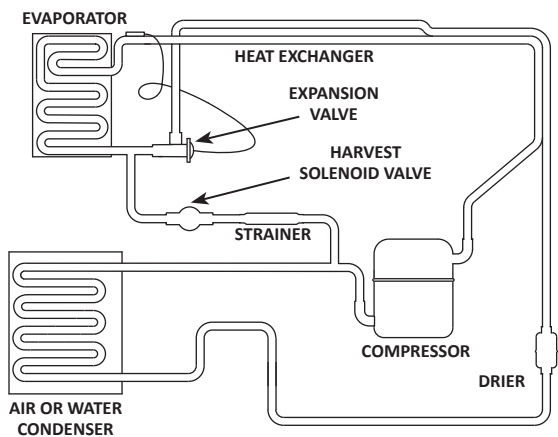

**SPACE FOR TECHNICIAN'S NOTES**

**SPACE FOR TECHNICIAN'S NOTES**

**SPACE FOR TECHNICIAN'S NOTES**

**SPACE FOR TECHNICIAN'S NOTES**





ICETRO AMERICA  
1202 W STRCUK AVE  
ORANGE, CA 92867

---

(714) 215-4864  
[WWW.ICETROAMERICA.COM](http://WWW.ICETROAMERICA.COM)

